

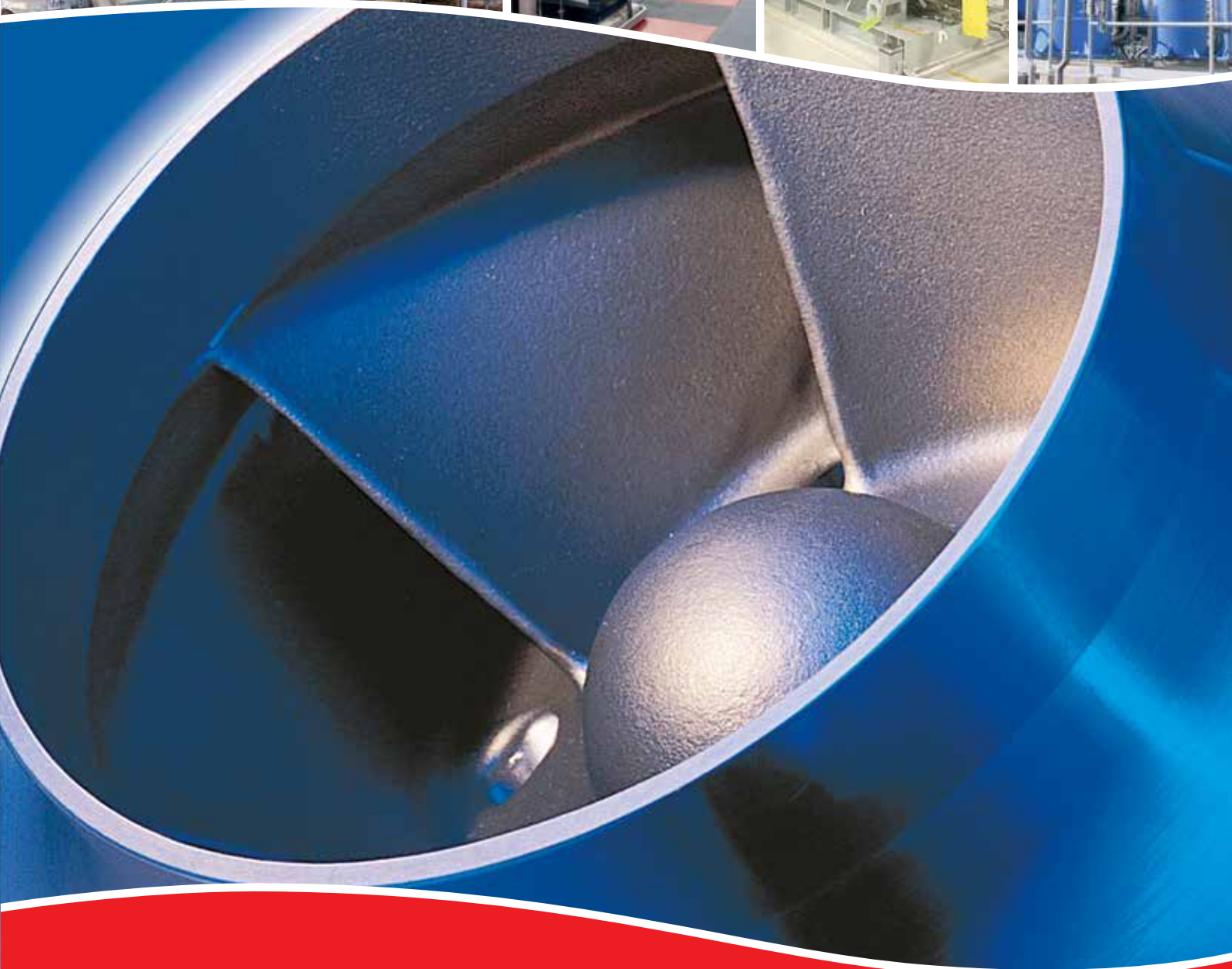

## *Pump Product Catalog*



*Experience In Motion*



## ***Pump Supplier to the World***

*Flowserve is the driving force in the global industrial pump marketplace. No other pump company in the world has the depth or breadth of expertise in the successful application of pre-engineered, engineered, and special purpose pumps and systems.*



### ***Product Brands of Distinction***

*AGEC™ Centrifugal Pumps*

*Aldrich™ Pumps*

*Byron Jackson® Pumps*

*Calder™ Energy Recovery Devices*

*Cameron™ Pumps*

*Durco® Process Pumps*

*Flowserve® Pumps*

*IDP® Pumps*

*INNOMAG® Sealless Pumps*

*Lawrence Pumps®*

*Niigata Worthington™ Pumps*

*Pacific® Pumps*

*Pleuger® Pumps*

*Scienco™ Pumps*

*Sier-Bath® Rotary Pumps*

*TKL™ Pumps*

*United Centrifugal® Pumps*

*Western Land Roller™ Irrigation Pumps*

*Wilson-Snyder® Pumps*

*Worthington® Pumps*

*Worthington Simpson™ Pumps*



### ***Pump Designs***

Flowserve offers a wide range of complementary pump types, built to recognized global standards and customer specification. These include:

- Single-stage process
- Between bearings single-stage
- Between bearings multistage
- Vertical
- Submersible motor
- Positive displacement
- Nuclear
- Specialty

### ***Available Configurations***

- Sealed and sealless
- Axially and radially split
- Volute and diffuser
- Close coupled and spacer coupled
- Single and double case



### ***Committed to the Complete Pump System Life Cycle***

For more than two centuries, Flowserve has served industries requiring solutions that add value and reduce costs throughout the life cycle of a pumping system.

- Oil and gas
- Chemical
- Power generation
- Water
- General industry

Flowserve partners with customers to respond to the dynamic business conditions that affect them and to improve efficiency, maximize throughput and control process quality. Whether customer needs involve on-site technical assistance, equipment upgrades or broader project planning with full turnkey responsibility, Flowserve delivers professional, reliable results.





## A Guide to Flowserve Pumps

*The purpose of this publication is to provide a brief summary of the hundreds of pumps that comprise the Flowserve product line. Pump models are divided into five sections, beginning with overhung pumps and continuing through specialty designs. Each pump is identified by its formal designation and accompanied by a full-color cutaway illustration. Applicable engineering standards are listed along with performance characteristics and key features. The symbols shown at right are used to identify each pump's primary market applications.*

For more information about Flowserve pumps, visit:  
[www.flowserve.com](http://www.flowserve.com)



**Oil and Gas**



**Chemical**



**Power**



**Water Resources**



**Mining**



**Pulp and Paper**



**Primary Metals**



**General Industry**



## Table of Contents

Pump Selection Guide ..... 6–7

### **Overhung Pumps**

Product List ..... 9  
 Chemical Process ..... 10–15  
 API Process ..... 16–18  
 Slurry and Solids Handling ..... 19–22  
 Industrial Process ..... 23–25

### **Between Bearings Pumps**

Product List ..... 27  
 Single Case—Axially Split—Single-Stage ..... 28–29  
 Single Case—Axially Split—Multistage ..... 30  
 Single Case—Radially Split—Single-Stage ..... 31  
 Single Case—Radially Split—Multistage ..... 32–34  
 Double Case ..... 35–37

### **Vertical Pumps**

Product List ..... 39  
 Wet-Pit ..... 40–41  
 Double Case ..... 42–43  
 Submersible ..... 44  
 Slurry and Solids Handling ..... 45–47  
 Sump ..... 48–49

### **Positive Displacement**

Product List ..... 51  
 Gear ..... 52  
 Screw ..... 53  
 Reciprocating ..... 54

### **Specialty Products**

Product List ..... 57  
 Nuclear Pumps and Seals ..... 58–61  
 Extreme Temperature Pumps ..... 62  
 Others ..... 63–65

### **Additional Information**

Introduction ..... 67  
 Integrated Solutions Group ..... 68–69  
 Other Flowserve Products ..... 70  
 Reference Sources ..... 71

### **Index**

Product List ..... 72–73









## Overhung Pumps

### Chemical Process

Mark 3™ ASME Standard	10
Mark 3 Lo-Flo™	10
Mark 3 Unitized Self-Primer	10
Mark 3 Recessed Impeller	11
Mark 3 In-Line	11
Guardian Magnetic Drive	11
Mark 3 ISO Standard	12
Mark 3 ISO Self-Priming	12
Mark 3 ISO Recessed Impeller	12
Mark 3 ISO Close Coupled	13
CPXV Chemical Sump	13
CPXS Magnetic Drive	13
PolyChem™ GRP	14
PolyChem VGRP	14
PolyChem S-Series	14
PolyChem M-Series	15
Polyshield	15
Polybase	15

### API Process

HPX	16
HPXM	16
PHL	16
ERP/N	17
PVXM	17
HWMA	17
PVML	18
MSP	18
DSVP	18

### Slurry and Solids Handling

M	19
R	19
Titan Slurry™	19
LC	20
MND	20
MNR	20
FRBH	21
FRBHJC	21
MPT	21
MF	22
MN	22
MSX	22

### Industrial Process

D800	23
MEN	23
MENBLOC	23
ME	24
DS	24
SMP	24
SMX	25
F-Line	25
MVE	25

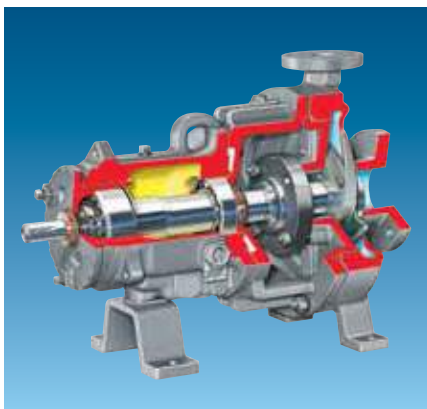

**Mark 3 ASME Standard****Standards**

- ASME (ANSI) B73.1

**Operating Parameters**

- Flows to 4540 m<sup>3</sup>/h (20 000 gpm)
- Heads to 215 m (700 ft)
- Pressures to 27 bar (400 psi)
- Temperatures from -73°C (-100°F) to 370°C (700°F)

**Features**

- Exclusive reverse vane impeller
- Standard Mark 3A power end
  - External micrometer impeller adjustment mechanism
  - Heavy-duty radial and thrust bearings
  - Double lip oil seals
  - Constant level oiler
  - Large, reflective sight glass
- Choice of lubrication systems
- Optional ANSI 3A power end with lifetime warranty
  - Certified clean room assembly
  - Inpro/Seal® VBXX isolators
  - Magnetic drain plug
- SealSentry™ seal chambers
- Largest shaft and bearing components in ANSI standard pumps
- IPS Beacon™ electronic vibration and temperature condition monitor

**Related Configurations**

- Mark 3 Lo-Flo
- Mark 3 Unitized Self-Primer
- Mark 3 Recessed Impeller
- Mark 3 Sealmatic dynamically sealed

See Bulletin PS-10-13.

**Mark 3 Lo-Flo****Standards**

- ASME (ANSI) B73.1

**Operating Parameters**

- Flows to 50 m<sup>3</sup>/h (220 gpm)
- Heads to 300 m (985 ft)
- Pressures to 31 bar (450 psi)
- Temperatures from -73°C (-100°F) to 370°C (700°F)

**Features**

- Circular, concentric casing
- Radial vane impeller
- Standard Mark 3A power end
  - External micrometer impeller adjustment mechanism
  - Heavy-duty radial and thrust bearings
  - Double lip oil seals
  - Constant level oiler
  - Large, reflective sight glass
- Choice of lubrication systems
- Optional ANSI 3A power end with lifetime warranty
  - Certified clean room assembly
  - Inpro/Seal VBXX isolators
  - Magnetic drain plug
- SealSentry seal chambers
- Oversized shaft and bearings
- IPS Beacon electronic vibration and temperature condition monitor

**Related Configurations**

- Mark 3 ASME Standard
- Mark 3 Recessed Impeller

See Bulletin PS-10-13.

© Inpro/Seal is a registered trademark of Inpro/Seal Company.

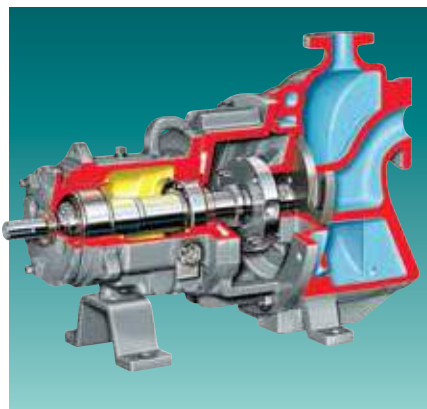
**Mark 3 Unitized Self-Primer****Standards**

- Flowserve

**Operating Parameters**

- Flows to 320 m<sup>3</sup>/h (1400 gpm)
- Heads to 120 m (400 ft)
- Pressures to 20 bar (285 psi)
- Temperatures to 370°C (700°F)
- Static suction lift to 6 m (20 ft)

**Features**

- Unitized casing with large priming chamber, air separator and volute
- Exclusive reverse vane impeller standard; open impeller optional
- Standard Mark 3A power end
  - External micrometer impeller adjustment mechanism
  - Heavy-duty radial and thrust bearings
  - Double lip oil seals
  - Constant level oiler
  - Large, reflective sight glass
- Choice of lubrication systems
- Optional ANSI 3A power end with lifetime warranty
  - Certified clean room assembly
  - Inpro/Seal VBXX isolators
  - Magnetic drain plug
- SealSentry seal chambers
- Oversized shaft and bearings
- IPS Beacon electronic vibration and temperature condition monitor

**Related Configurations**

- Mark 3 ASME Standard

See Bulletin PS-10-13.

## Mark 3 Recessed Impeller



### Standards

- Flowserve

### Operating Parameters

- Flows to 455 m<sup>3</sup>/h (2000 gpm)
- Heads to 120 m (400 ft)
- Pressures to 20 bar (285 psi)
- Temperatures from -73°C (-100°F) to 370°C (700°F)

### Features

- Low shear vortex pumping action
- Fractional media contact with the impeller
- Standard CD4MCuN impeller
- Thick-wall wet end components suitable for light slurries
- Standard Mark 3A power end
  - External micrometer impeller adjustment mechanism
  - Heavy-duty radial and thrust bearings
  - Double lip oil seals
  - Constant level oiler
  - Large, reflective sight glass
- Optional ANSI 3A power end with lifetime warranty
  - Certified clean room assembly
  - Inpro/Seal VBXX isolators
  - Magnetic drain plug
- SealSentry seal chambers
- Oversized shaft and bearings
- IPS Beacon electronic vibration and temperature condition monitor

### Related Configurations

- Mark 3 ASME Standard
- Mark 3 Sealmatic, recessed impeller

See Bulletin PS-10-13.

## Mark 3 In-Line

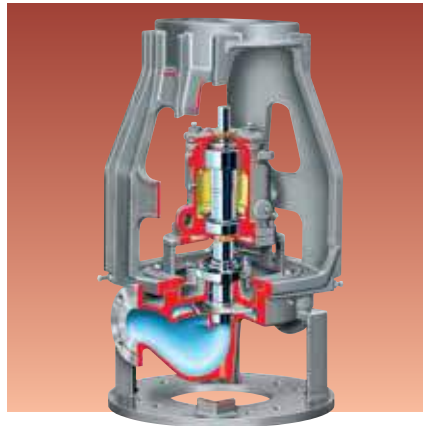

### Standards

- ASME (ANSI) B73.2

### Operating Parameters

- Flows to 370 m<sup>3</sup>/h (1630 gpm)
- Heads to 230 m (755 ft)
- Pressures to 24 bar (350 psi)
- Temperatures from -73°C (-100°F) to 370°C (700°F)

### Features

- Exclusive reverse vane impeller
- Standard Mark 3A power end
  - External micrometer impeller adjustment mechanism
  - Heavy-duty radial and thrust bearings
  - Double lip oil seals
- Optional ANSI 3A power end with lifetime warranty
  - Certified clean room assembly
  - Inpro/Seal VBXX isolators
- SealSentry seal chambers
- Unique C-plus motor and pump shaft alignment system
- Choice of bearing lubrication
  - Regreasable bearings
  - Oil mist
  - Permanently lubricated bearings

### Related Configurations

- Mark 3 In-Line, recessed impeller

See Bulletin PS-10-15.

## Guardian Magnetic Drive

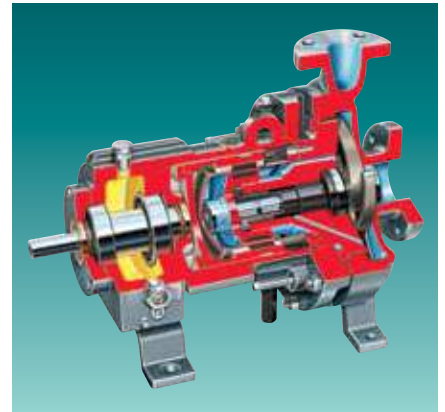

### Standards

- ASME (ANSI) B73.1 dimensions

### Operating Parameters

- Flows to 375 m<sup>3</sup>/h (1650 gpm)
- Heads to 215 m (700 ft)
- Pressures to 24 bar (350 psi)
- Temperatures from -73°C (-100°F) to 290°C (550°F)

### Features

- Magnetic drive design
- Alloy C-276 containment shell
- Rare earth magnets
- Low NPSHR, reverse vane impeller
- Casings and impellers interchangeable with sealed configuration
- Optimized internal lubrication path
- Silicon carbide bushings and journals with double spiral grooves
- Standard and contained back pullout
- Options
  - Fiber optic leak detection
  - Containment shell temperature probes
  - Process temperature probes
  - External flush plans

### Available Configurations

- G-Series: -75°C (-100°F) to 120°C (250°F)
- H-Series: -120°C (-250°F) to 290°C (550°F)

See Bulletin P-10-14.

### Mark 3 ISO Standard

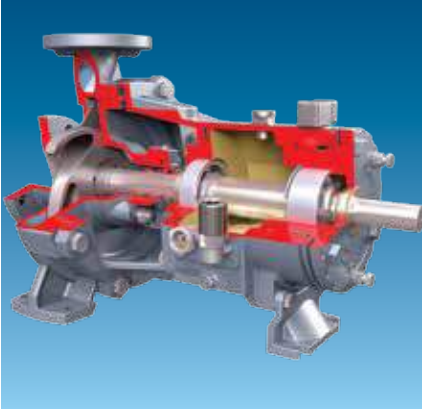

#### Standards

- ISO 2858
- ISO 5199

#### Operating Parameters

- Flows to 1400 m<sup>3</sup>/h (6160 gpm)
- Heads to 220 m (720 ft)
- Pressures to 25 bar (365 psi)
- Temperatures from -80°C (-110°F) to 400°C (752°F)

#### Features

- Heavy-duty casing with integral foot and multi-ribbed discharge flange
- Reverse vane impeller standard; open impeller available
- SealSentry seal chambers
- Accepts multiple seal arrangements
- External micrometer impeller adjustment mechanism
- Standard non-contacting labyrinth seal
- Heavy-duty radial and thrust bearings
- Two-piece bearing housing
- Back pullout design
- IPS Beacon electronic vibration and temperature condition monitor
- Optional ISO 3A power end with lifetime warranty
- CE marked; ATEX compliant; GOST certificate available

#### Related Configurations

- Mark 3 ISO Self-Priming
- Mark 3 ISO Recessed Impeller
- Mark 3 ISO Close Coupled
- CPXV Chemical Sump
- Mark 3 ISO centerline mounted

See Bulletin PS-10-31.

### Mark 3 ISO Self-Priming

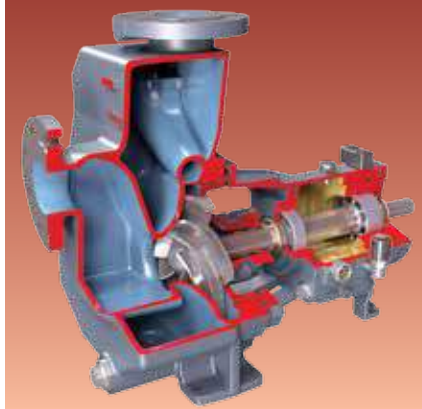

#### Standards

- ISO 2858
- ISO 5199

#### Operating Parameters

- Flows to 100 m<sup>3</sup>/h (440 gpm)
- Heads to 100 m (330 ft)
- Pressures to 25 bar (365 psi)
- Temperatures from -80°C (-110°F) to 400°C (752°F)

#### Features

- One-piece casing with integral priming chamber, air separator and volute
- High-efficiency, front vane, open-style impeller with low NPSHR
- Run-dry capability
- SealSentry seal chambers
- Accepts multiple seal arrangements
- External micrometer impeller adjustment mechanism
- Standard non-contacting labyrinth seal
- Heavy-duty radial and thrust bearings
- Back pullout design
- IPS Beacon electronic vibration and temperature condition monitor
- Optional ISO 3A power end with lifetime warranty
- CE marked; ATEX compliant; GOST certificate available

#### Other Configurations

- Mark 3 ISO Close Coupled, Self-Priming
- Mark 3 ISO Magnetic Drive, Self-Priming

See Bulletin PS-10-31.

### Mark 3 ISO Recessed Impeller

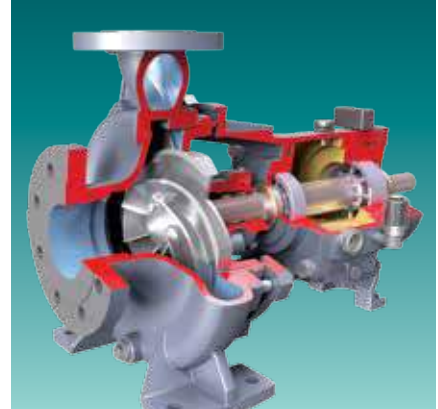

#### Standards

- ISO 2858
- ISO 5199

#### Operating Parameters

- Flows to 750 m<sup>3</sup>/h (3300 gpm)
- Heads to 100 m (330 ft)
- Pressures to 25 bar (365 psi)
- Temperatures from -80°C (-110°F) to 400°C (752°F)

#### Features

- Heavy-duty casing with integral foot and multi-ribbed discharge flange
- Vortex action minimizes abrasive wear and maintains solids integrity
- Standard front vane, open-style impeller precision cast in CD4MCuN
- SealSentry seal chambers
- Accepts multiple seal arrangements
- External micrometer impeller adjustment mechanism
- Standard non-contacting labyrinth seal
- Heavy-duty radial and thrust bearings
- Two-piece bearing housing
- Back pullout design
- IPS Beacon electronic vibration and temperature condition monitor
- Optional ISO 3A power end with lifetime warranty
- CE marked; ATEX compliant; GOST certificate available

#### Other Configurations

- CPXV Recessed Impeller, Sump
- Mark 3 ISO Close Coupled, Recessed Impeller

See Bulletin PS-10-31.

## Mark 3 ISO Close Coupled



### Standards

- ISO 2858
- ISO 5199

### Operating Parameters

- Flows to 750 m<sup>3</sup>/h (3300 gpm)
- Heads to 100 m (330 ft)
- Pressures to 25 bar (365 psi)
- Temperatures from -80°C (-110°F) to 160°C (320°F)

### Features

- Compact, space-saving configuration
- Investment cast muff coupling
- Heavy-duty casing with integral foot and multi-ribbed discharge flange
- Radiating surfaces
- Reverse vane impeller standard; front vane, open-style impeller available
- SealSentry seal chambers
- Accepts multiple seal arrangements
- External micrometer impeller adjustment mechanism
- Accepts standard electric motors
- Standard non-contacting labyrinth seal
- Back pullout design
- CE marked; ATEX compliant; GOST certificate available

### Other Configurations

- Mark 3 ISO Close Coupled, Recessed Impeller
- Mark 3 ISO Close Coupled, Self-Priming

See Bulletin PS-10-31.

## CPXV Chemical Sump



### Standards

- ISO 13709/API 610, 8th & 10th ed.
- ISO 5199

### Operating Parameters

- Flows to 1400 m<sup>3</sup>/h (6160 gpm)
- Heads to 250 m (820 ft)
- Pressures to 25 bar (365 psi)
- Temperatures from -40°C (-40°F) to 400°C (752°F)

### Features

- Heavy-duty casing with multi-ribbed discharge flange
- High-efficiency, front vane, open-style impeller
- Column lengths to 10 m (32 ft)
- Heavy-duty thrust bearings with axial adjustment above soleplate level
- Accepts multiple seal arrangements
- Elastomeric split element coupling
- Options
  - Recessed impeller
  - Suction strainer
  - Spacer coupling
  - Rectangular or circular soleplate
  - Oil lubrication to thrust bearing
  - Zone Ø hazardous area beneath soleplate configuration
- CE marked; ATEX compliant; GOST certificate available

### Other Configurations

- CPXV Recessed Impeller, Sump
- Fully jacketed, molten salt design

See Bulletin PS-10-31.

## CPXS Magnetic Drive

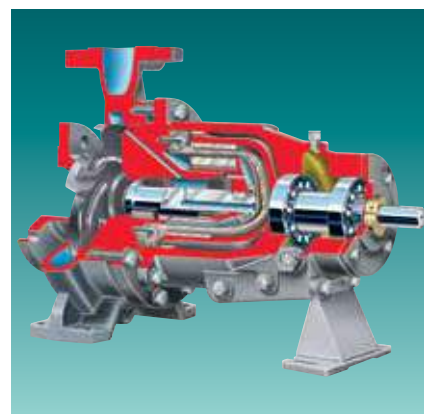

### Standards

- ISO 2858
- ISO 15783

### Operating Parameters

- Flows to 420 m<sup>3</sup>/h (1850 gpm)
- Heads to 160 m (525 ft)
- Pressures to 25 bar (365 psi)
- Temperatures from -40°C (-40°F) to 250°C (480°F)

### Features

- Reinforced PEEK® or Alloy C-276 primary containment shell
- Optional Alloy C-276 secondary containment shell
- High-performance rare earth magnets
- Large inner magnet clearances
- Optimized internal flow circulation path
- Heavy-duty casing with integral foot and multi-ribbed discharge flange
- High-efficiency, front vane, open-style impeller with low NPSHR
- Advanced sintered silicon carbide bushings and journal bearings
- Standard and contained back pullout design
- CE marked; ATEX compliant; GOST certificate available

### Other Configurations

- Mark 3 ISO Close Coupled, Magnetic Drive
- Mark 3 ISO Magnetic Drive, Self-Priming

See Bulletin PS-10-31.

© PEEK is a registered trademark of Victrex plc Corp.

## PolyChem GRP Engineered Polymer Composite

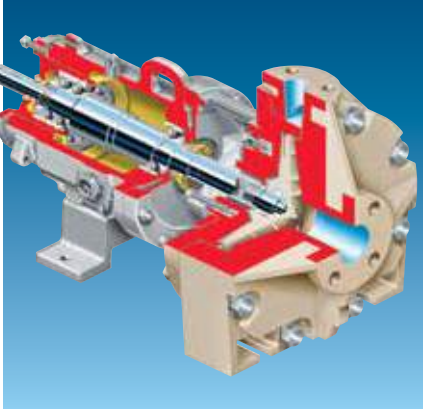

### Standards

- ASME (ANSI) B73.5

### Operating Parameters

- Flows to 2050 m<sup>3</sup>/h (9000 gpm)
- Heads to 150 m (500 ft)
- Pressures to 17 bar (250 psi)
- Temperatures from -45°C (-50°F) to 120°C (250°F)

### Features

- Glass-reinforced vinyl ester
- Unitized casing with integrally molded, fully gusseted suction and discharge flanges
- Tapered polygon impeller drive
- Seal chamber accommodates multiple seals, glands and flush arrangements
- Standard Mark 3A power end
  - External micrometer impeller adjustment mechanism
  - Heavy-duty radial and thrust bearings
  - Double lip oil seals
  - Constant level oiler
- Optional ANSI 3A power end with lifetime warranty
  - Certified clean room assembly
  - Inpro/Seal VBXX isolators
  - Magnetic drain plug
- IPS Beacon electronic vibration and temperature condition monitor

### Related Configurations

- PolyChem VGRP engineered polymer composite sump
- Self-primer

See Bulletin PS-10-17.

## PolyChem VGRP Engineered Polymer Composite Sump

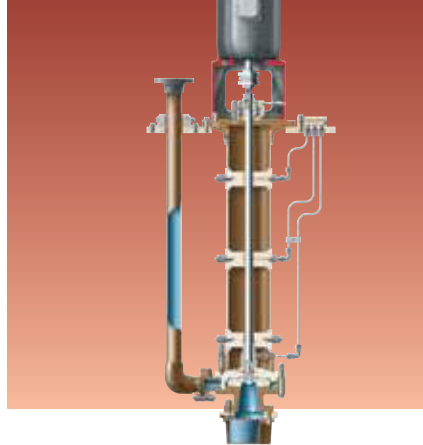

### Standards

- Flowserve

### Operating Parameters

- Flows to 565 m<sup>3</sup>/h (2500 gpm)
- Heads to 110 m (350 ft)
- Pressures to 17 bar (250 psi)
- Temperatures from -30°C (-20°F) to 90°C (200°F)

### Features

- Glass-reinforced vinyl ester
- Unitized casing with integrally molded, fully gusseted suction and discharge flanges
- Externally adjustable, semi-open impeller
- Shaft and bearing system operates well below the first critical speed
- Self-lubricated or external flush bearings
- Single-piece, lightweight, filament-wound, reinforced fiberglass composite column
- Single and duplex configurations
- Full basket strainer
- NEMA TCV motor
- Fiberglass mounting plate
- Tapered polygon impeller drive
- Pullout bearing retainers
- Level controls
- Choice of shaft metallurgy

### Related Configurations

- PolyChem GRP engineered polymer composite

See Bulletin PS-10-17.

## PolyChem S-Series Fluoropolymer Lined

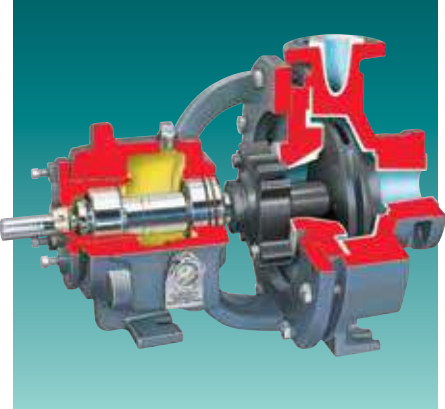

### Standards

- ASME (ANSI) B73.1
- ISO 2858
- JIS drilling

### Operating Parameters

- Flows to 420 m<sup>3</sup>/h (1850 gpm)
- Heads to 145 m (480 ft)
- Pressures to 17 bar (250 psi)
- Temperatures from -30°C (-20°F) to 150°C (300°F)

### Features

- PFA-lined wet end
- Metal armor meets material specifications of ASTM A395 and GGG 40.3
- Enclosed impeller standard; open impeller optional
- Standard Mark 3A power end
- SealSentry seal chamber accommodates multiple seal types
- Choice of solid or sleeved shaft
- Bearing housing options
  - Labyrinth oil seals
  - Oil slinger
  - Regreasable or double-shielded bearings
  - Oil mist lubrication
- Optional ANSI 3A power end with lifetime warranty
  - Certified clean room assembly
  - Inpro/Seal VBXX isolators
  - Magnetic drain plug
- IPS Beacon electronic vibration and temperature condition monitor

See Bulletin PS-10-17.

## PolyChem M-Series Fluoropolymer Lined, Magnetic Drive



### Standards

- ASME (ANSI) B73.1
- ISO 2858
- JIS drilling

### Operating Parameters

- Flows to 135 m<sup>3</sup>/h (600 gpm)
- Heads to 145 m (480 ft)
- Pressures to 17 bar (250 psi)
- Temperatures from -30°C (-20°F) to 150°C (300°F)

### Features

- PFA-lined wet end
- Ductile cast iron casing with 3 mm (0.1 in) minimum PFA liner
- PFA-lined fiberglass containment shell
- Enclosed PFA-lined impeller
- Rare earth magnets in synchronous drive
- Metal armor meets material specifications of ASTM A395 and GGG40.3
- Separate inner magnet and impeller components
- Rotating shaft design
- Silicon carbide radial and axial thrust bearings
- Choice of bearing lubrication
- Options
  - Long and close coupled designs
  - ANSI 3A power end

See Bulletin PS-10-17.

## Polyshield Baseplate and Foundation System

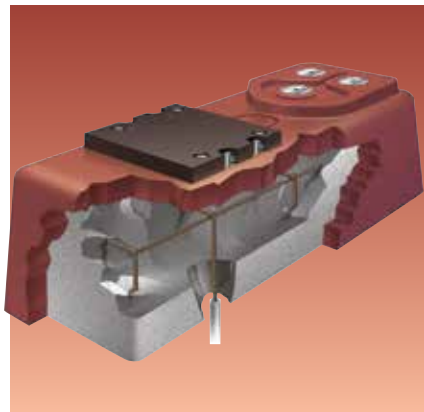

### Standards

- Flowserve

### Operating Parameters

- Temperatures to 260°C (500°F)

### Features

- Combines non-metallic baseplate and formed concrete foundation for pump driver in one complete unit
- Excellent corrosion resistance
- Improved vibration dampening
- Reduced installation costs and time
- Solid one-piece polymer motor mounting block with four 304 SS transverse motor block adjusters
- Self-venting design with grout hole and plug
- Standard 316 stainless steel inserts
- Integral catch basin with NPT connection
- Uses 200 bar (3000 psi) concrete
- Suitable with ANSI, ISO, API and other foot-mounted and centerline mounted pumps
- Outstanding flatness
- Options
  - Choice of three polymer materials
  - Alloy 20 and Alloy C-276 inserts available
  - CPVC drain connection

See Bulletin PS-90-2.

## Polybase Polymer Concrete Baseplate

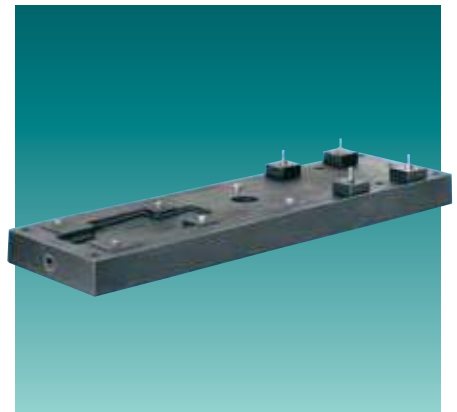
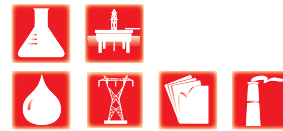

### Standards

- ANSI and ISO standard designs

### Features

- Solid polymer concrete construction
- Low installed cost
- Superior flatness
- Enhanced vibration dampening
- Excellent corrosion resistance
- Outstanding resistance to twisting or diaphragming
- 8-point™ adjuster alignment system
- Choice of three polymer materials
- Options
  - Polybloc™ motor mounting blocks
  - Catch basin
  - Grout hole
  - Alternate equipment inserts

See Bulletin PS-10-13.

## HPX (OH2) Centerline Mounted



### Standards

- ISO 13709/API 610 (OH2), latest ed.

### Operating Parameters

- Flows to 2000 m<sup>3</sup>/h (8800 gpm)
- Heads to 350 m (1100 ft)
- Pressures to 80 bar (1160 psi)
- Temperatures from -160°C (-250°F) to 450°C (842°F)

### Features

- Centerline-supported casing
- Nozzle loading capability beyond ISO 13709/API 610 requirements
- Dynamically balanced impeller
- Rugged shaft design
- ISO 21049/API 682 seal chamber accommodates multiple seal types
- Choice of bearings
  - Standard single row, deep groove, radial bearing and duplex, single row 40° angular contact thrust bearings
  - Special bearing arrangements for high suction pressures
- Bearing lubrication and cooling options
  - Oil mist and oil purge
  - Fan cooling
  - Finned cooling insert

### Related Configurations

- HPXT centerline mounted, top suction
- HPXH centerline mounted, high suction pressure
- HPXSL centerline mounted, slurry
- HPXIND centerline mounted, inducer
- HPXCC centerline mounted, coke crusher

See Bulletin PS-10-5.

## HPXM (OH2) Centerline Mounted, Low-Flow

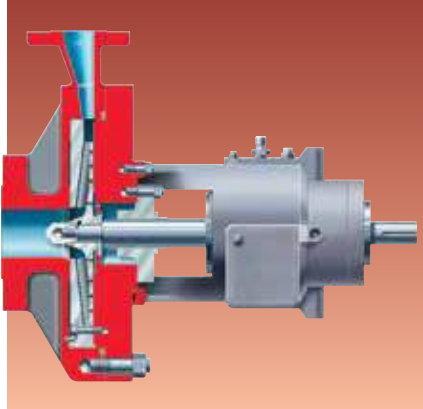

### Standards

- ISO 13709/API 610 (OH2), latest ed.

### Operating Parameters

- Flows to 30 m<sup>3</sup>/h (130 gpm)
- Heads to 280 m (920 ft)
- Pressures to 80 bar (1160 psi)
- Temperatures from -160°C (-250°F) to 450°C (842°F)

### Features

- Low-flow, high-head design
- Replaceable volute inserts
- High-efficiency radial blade impeller
- Full interchangeability with HPX bearing assembly and mechanical seals
- Choice of bearings
  - Standard single row, deep groove, radial bearing and duplex, single row 40° angular contact thrust bearings
  - Special bearing arrangements for high suction pressures
- ISO 21049/API 682 seal chamber accommodates multiple seal types
- Bearing lubrication and cooling options
  - Oil mist and oil purge
  - Fan cooling
  - Finned cooling insert
- Optional inducer

### Related Configurations

- HPX centerline mounted

See Bulletin PSS-10-5.1.

## PHL (OH2) Centerline Mounted

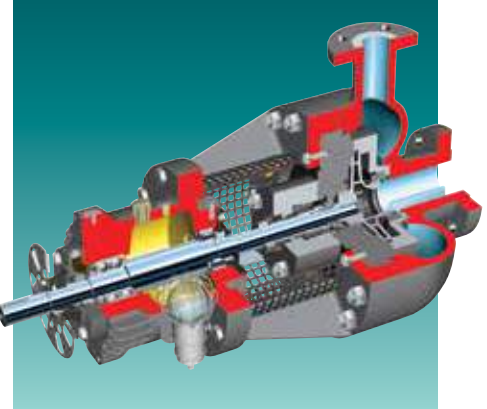

### Standards

- ISO 13709/API 610 (OH2), latest ed.

### Operating Parameters

- Flows to 900 m<sup>3</sup>/h (4000 gpm)
- Heads to 400 m (1300 ft)
- Pressures to 40 bar (600 psi)
- Temperatures from -160°C (-250°F) to 450°C (842°F)
- Motor sizes to 110 kW (150 hp)

### Features

- Centerline-supported, end suction casing
- Custom-tuned hydraulics
- Multi-channel diffuser technology
  - Customized BEP fits
  - High efficiency
  - Extended MTBR
  - Low vibration
  - Low noise
- Low shaft deflection at any flow
- ISO 21049/API 682 seal chamber accommodates multiple seal types including dual pressurized, unpressurized and gas
- Bearing housing cooling options
  - Air fan
  - Water jacket
- Replaceable diffusers
- Available boron diffusion surface treatment

### Other Configurations

- Top suction nozzle

See Bulletin PSS-10-5.2.



## ERP Centerline Mounted

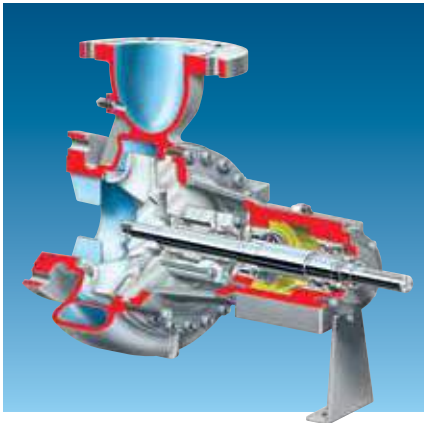

### Standards

- Flowserve

### Operating Parameters

- Flows to 1100 m<sup>3</sup>/h (4800 gpm)
- Heads to 230 m (750 ft)
- Pressures to 60 bar (870 psi)
- Temperatures to 350°C (660°F)

### Features

- Critical parameters meet ISO 13709/API 610 (OH2)
  - Vibration limits
  - Deflection limits at seal faces
  - Nozzle loading capabilities
  - Balancing grades
- ISO 21049/API 682 seal chamber accommodates multiple seal types
- Dynamically balanced, high-efficiency impeller
- Centerline-supported casing
- Double volute design for discharge flanges 80 mm (3 in) and larger
- Renewable casing and cover wear rings
- Back pullout design
- Optional inducer
- Choice of API materials

### Related Configurations

- ERP-O semi-open impeller
- High suction pressure: 35 bar (500 psi)

See Bulletin PS-10-20.

## PVXM (OH3) Vertical In-Line

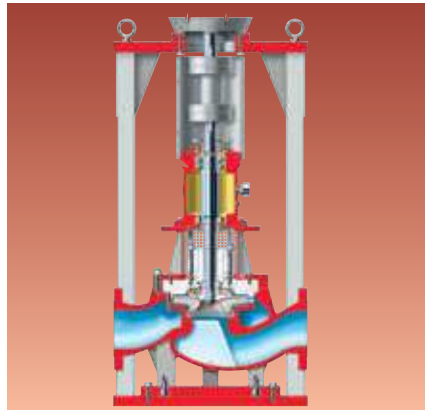

### Standards

- ISO 13709/API 610 (OH3), latest ed.

### Operating Parameters

- Flows to 500 m<sup>3</sup>/h (2200 gpm)
- Heads to 275 m (900 ft)
- Pressures to 40 bar (600 psi)
- Temperatures from -100°C (-148°F) to 250°C (480°F)

### Features

- Space-saving design
- Precision-machined diffusers
- Customizable hydraulics — 150 BEP hydraulic fits with 10 casings
- Casing and cover design with metal-to-metal fits and fully confined compression gasket
- ASME (ANSI) B16.5 Class 300 raised face flanges
- Dynamically balanced impeller
- Optimized NPSHR due to suction box design
- ISO 21049/API 682 seal chamber
- Heavy-duty motor support head fits NEMA, C-Face and IEC drivers
- 100% back pullout design
- Flexible disc spacer coupling
- Upper and lower labyrinth bearing isolators; optional radial lip seals
- Bearing lubrication options
  - Oil cascade
  - Oil mist
  - Grease lube

### Related Configurations

- PVML vertical in-line

See Bulletin PS-10-29.

## HWMA (OH3) Vertical In-Line, Low-Flow, High-Head

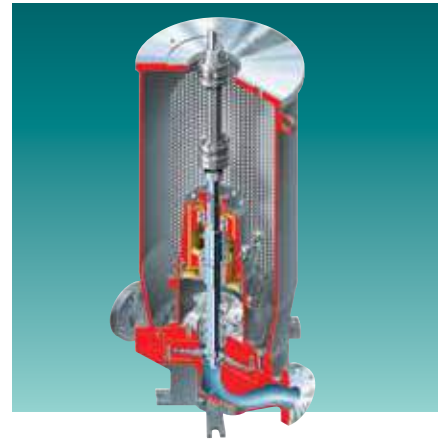

### Standards

- ISO 13709/API 610 (OH3), latest ed.

### Operating Parameters

- Flows to 45 m<sup>3</sup>/h (200 gpm)
- Heads to 440 m (1455 ft)
- Pressures to 60 bar (870 psi)
- Temperatures from -50°C (-58°F) to 260°C (500°F)

### Features

- Space-saving design
- Low-flow, high-head hydraulics
- Replaceable volute inserts
- Customizable hydraulics — 80 BEP fits in a single pump size
- Casing and cover design with metal-to-metal fits and fully confined compression gasket
- ASME (ANSI) B16.5 Class 600 raised face flanges; flat face optional
- Radial blade impeller
- Optional inducer for low NPSHR
- ISO 21049/API 682 seal chamber
- Heavy-duty motor support head fits NEMA, C-Face, P-base and IEC drivers
- 100% back pullout design
- Flexible disc spacer coupling
- Upper labyrinth bearing isolator; optional radial lip seals
- Choice of bearing lubrication systems

### Related Configurations

- WMA rigidly coupled, vertical in-line
- HWMA2 two-stage, vertical in-line
- WMA2 rigidly coupled, two-stage, vertical in-line

See Bulletin PS-10-25.

**PVML (OH5)**  
**Vertical In-Line**

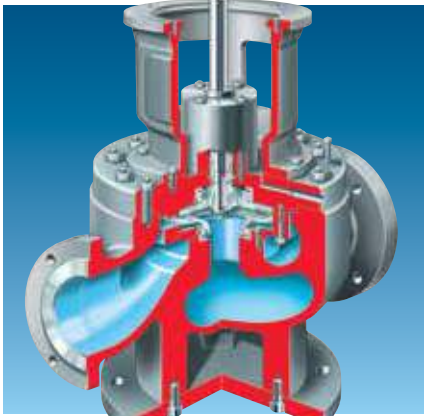

**Standards**

- ISO 13709/API 610 (OH5), latest ed.
- BS 4082R

**Operating Parameters**

- Flows to 500 m<sup>3</sup>/h (2200 gpm)
- Heads to 275 m (900 ft)
- Pressures to 40 bar (580 psi)
- Temperatures from -100°C (-148°F) to 250°C (480°F)

**Features**

- Space-saving, alignment-free design
- Custom-tuned hydraulics
- State-of-the-art diffuser technology
  - Customized BEP fits
  - High efficiency
  - Extended MTBR
  - Low vibration
  - Low noise
- ISO 21049/API 682 seal chamber accommodates multiple seal types
- Dynamically balanced impeller
- Positively locked, anti-rotation impeller nut with threads unexposed to pumped fluid

**Related Configurations**

- PVXM vertical in-line

See Bulletin PS-10-28.

**MSP**  
**Vertical In-Line,**  
**Medium Speed**



**Standards**

- Flowserve

**Operating Parameters**

- Flows to 27 m<sup>3</sup>/h (120 gpm)
- Heads to 900 m (2955 ft)
- Pressures to 60 bar (870 psi)
- Maximum suction pressure to 40 bar (580 psi)
- Temperatures from -40°C (-40°F) to 350°C (660°F)
- Speeds from 2000 rpm to 8000 rpm

**Features**

- Closely follows ISO 13709/API 610 (OH4), latest edition
- Modified concentric volute
- Open impeller with balance holes and scallops
- Variable frequency drive
- Rigid coupling
- Single- or dual-cartridge mechanical seals
- Options
  - Inducer
  - Choice of materials

**Available Configurations**

- Horizontal configuration
- MSP vertical in-line, single-stage
- MSP2 vertical in-line, two-stage (opposed impellers)

See Bulletin PS-10-1.

**DSVP (OH4)**  
**Vertical In-Line**

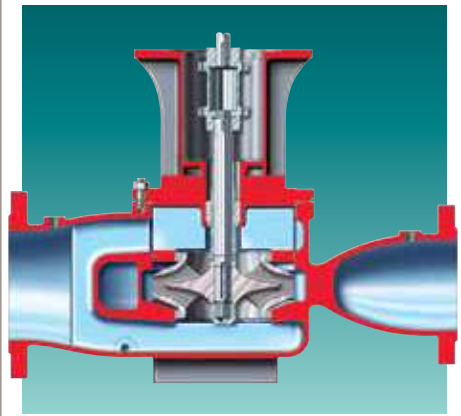

**Standards**

- ISO 13709/API 610 (OH4), latest ed.

**Operating Parameters**

- Flows to 3400 m<sup>3</sup>/h (15 000 gpm)
- Heads to 150 m (492 ft)
- Pressures to 40 bar (600 psi)
- Temperatures to 340°C (650°F)
- Motor ratings to 895 kW (1200 hp)

**Features**

- Space-saving design
- ISO 21049/API 682 seal chamber accommodates multiple seal types
- Double-suction enclosed impeller
- Double volute case design
- Standard case wear rings
- Optional impeller wear rings
- Metal-to-metal case to cover sealing with confined gasket
- Rigid spacer coupling
- Impeller nut design, threaded to tighten with rotation

**M**  
**Hard Metal,  
 Abrasive Slurry**

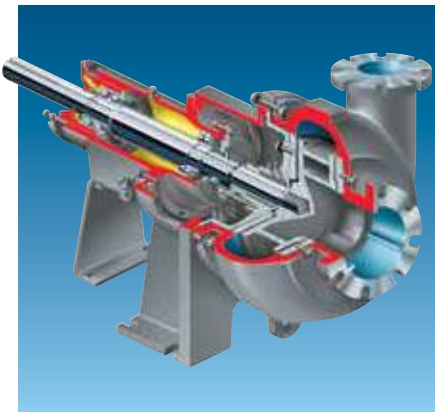

**Standards**  
 • Flowserve

**Operating Parameters**

- Flows to 10 000 m<sup>3</sup>/h (44 000 gpm)
- Heads to 90 m (300 ft)
- Pressures to 10 bar (150 psi); 50 bar (725 psi) with the high-pressure model
- Temperatures to 120°C (250°F)
- Solids from 2% to 70% by weight

**Features**

- One-piece high chrome iron, concentric casing with replaceable gland and suction side wear plates
- Closed impeller with pump-out vanes on front and rear shrouds
- Standard packing stuffing box with replaceable wear plate
- Full and low-flow flush connections
- Heavy-duty bearing frame designed for V-belt loads
- Cartridge style bearings
- Parts interchangeable with R pump
- Three-point external end clearance adjustment
- Options
  - Vortex semi-recessed impeller
  - Hard metal expeller
  - Mechanical seal housing

**Related Configurations**

- Severe-duty model
- High-pressure model
- MJ slurry sump
- MJC cantilever slurry sump

See Bulletin PS-10-19.

**R**  
**Radially Split,  
 Rubber-Lined Slurry**

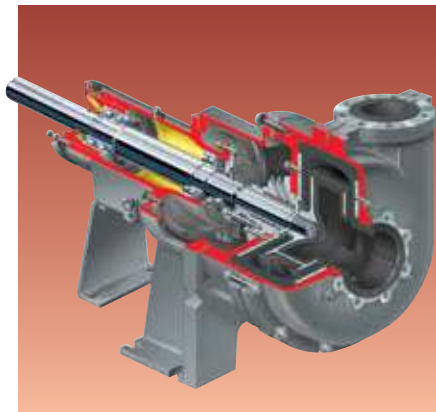

**Standards**  
 • Flowserve

**Operating Parameters**

- Flows to 10 000 m<sup>3</sup>/h (44 000 gpm)
- Heads to 50 m (165 ft)
- Pressures to 10 bar (150 psi) standard; 24 bar (350 psi) optional
- Temperatures to 110°C (225°F)
- Solids from 2% to 70% by weight

**Features**

- Concentric, cast iron casing with replaceable, abrasion-resistant rubber liner
- Rubber-lined, closed impeller with front and rear pump-out vanes
- Standard packing stuffing box with replaceable wear plate
- Full and low-flow flush connections
- Heavy-duty bearing frame
- Three-point external end clearance adjustment
- Parts interchangeable with M pump
- Directly coupled or V-belt driven
- Options
  - Acid-resistant stuffing box kits
  - Hard metal expeller
  - Mechanical seal housing
  - Choice of liner materials

**Related Configurations**

- RJ rubber-lined, slurry sump
- RJC cantilever rubber-lined, slurry sump

See Bulletin PS-10-18.

**Titan Slurry**  
**Heavy-Duty, Radially Split,  
 Lined Slurry**

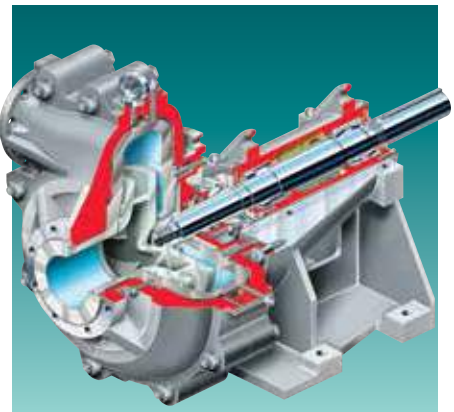

**Standards**  
 • Flowserve

**Operating Parameters**

- Flows to 3600 m<sup>3</sup>/h (16 000 gpm)
- Heads to 90 m (300 ft)
- Pressures to 40 bar (580 psi)
- Temperatures to 110°C (225°F)
- Sizes from 50 mm (2 in) to 350 mm (14 in)

**Features**

- Fully interchangeable elastomeric or hard metal liners
- Radially split casing
- High-efficiency, closed impeller
- Ample seal chamber accommodates a variety of packing and seal types
- Heavy-duty bearing frame sized to handle belt loads
- Bearing cartridge with back-to-back angular contact thrust bearings
- Roller-type radial bearings
- Contact lip seals
- Dimensionally compatible with the industry's most widely used pumps
- Optional expeller for dynamic sealing

**Available Configurations**

- Metal-lined model
- Rubber-lined model
- High-pressure model

See Bulletin PS-10-8.

**LC**  
**Chemical Slurry**

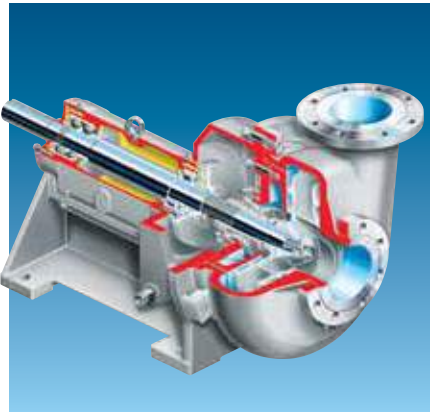

- Standards**
- Flowsolve

- Operating Parameters**
- Flows to 8000 m<sup>3</sup>/h (35 200 gpm)
  - Heads to 90 m (300 ft)
  - Pressures to 25 bar (360 psi)
  - Temperatures to 140°C (285°F)
  - Specific gravities to 1.7

- Features**
- Concentric casing with tangential discharge
  - Rigid, one-piece bearing frame with two angular contact outboard bearings and roller inboard bearings
  - Large diameter, heavy-duty shaft
  - Choice of shaft sealing options
    - Wet gland packing
    - Single or double mechanical seal
    - High-pressure double mechanical seal
    - Special high solids seals
    - Alumina industry seal
  - Choice of materials of construction
  - Multiple impeller designs
  - Direct-coupled or belt-driven
  - Choice of six drive arrangements
  - Options
    - Inducer
    - Stuffing box cooling system

- Related Configurations**
- PL-C cantilever, chemical slurry sump
  - LC-S lineshaft, chemical slurry sump

See Bulletin PS-10-11.

**MND**  
**Hard Metal**  
**Absorber Recirculation**

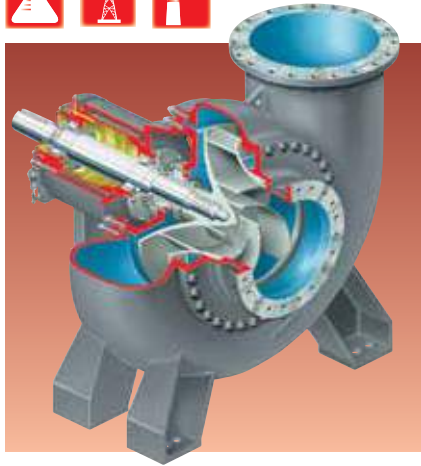

- Standards**
- Flowsolve

- Operating Parameters**
- Flows to 17 500 m<sup>3</sup>/h (77 000 gpm)
  - Heads to 40 m (130 ft)
  - Sizes from 600 mm (24 in) to 1000 mm (40 in)

- Features**
- One-piece, high-efficiency impeller with mixed flow vane design
  - Multiple materials of construction
  - Replaceable casing wear ring
  - Opposed tapered roller bearings designed for a minimum B10 life of 100 000 hours
  - Product flush slurry seal
  - External end clearance adjustment
  - Front and back pullout

- Related Configurations**
- Vertical mounting
  - MNR rubber-lined absorber recirculation

See Bulletin PS-10-32.

**MNR**  
**Rubber-Lined**  
**Absorber Recirculation**

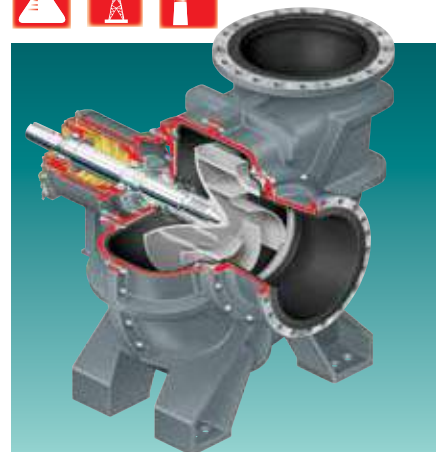

- Standards**
- Flowsolve

- Operating Parameters**
- Flows to 17 500 m<sup>3</sup>/h (77 000 gpm)
  - Heads to 40 m (130 ft)
  - Sizes from 600 mm (24 in) to 1000 mm (40 in)

- Features**
- One-piece, high-efficiency impeller with mixed flow vane design
  - Removable one-piece elastomeric casing liner
  - Radially split casing
  - Multiple materials of construction
  - Replaceable casing wear ring
  - Opposed tapered roller bearings designed for a minimum B10 life of 100 000 hours
  - Product flush slurry seal
  - External end clearance adjustment
  - Front and back pullout

- Related Configurations**
- Vertical mounting
  - MND hard metal absorber recirculation

See Bulletin PS-10-32.

**FRBH**  
**Heavy-Duty Paper Stock**  
**and Process**

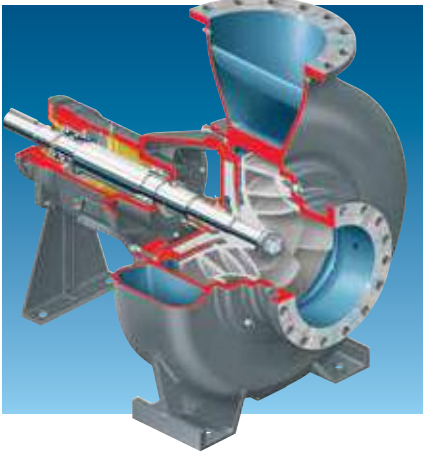

**Standards**

- Flowserve

**Operating Parameters**

- Flows to 9085 m<sup>3</sup>/h (40 000 gpm)
- Heads to 100 m (330 ft)
- Pressures to 14 bar (200 psi)
- Temperatures to 150°C (300°F)

**Features**

- Self-venting, top centerline discharge casing
- Semi-open, full vane impeller with back pump-out vanes
- Large suction inlet
- Seal chamber accepts packing or mechanical seal
- Three-point end clearance adjustment
- Back pullout design
- Heavy-duty, oil-lubricated bearings
- Fully split interlocking glands
- Extra heavy-duty alloy steel shaft
- Contoured wearplate match machined with impeller
- Dry shaft construction with sealed impeller nut and stainless steel hook sleeve
- Rigid, one-piece bearing frame
- Options
  - Large conical seal housing
  - Inducer
  - Expeller
  - Recessed impeller

**Related Configurations**

- FRBHJC cantilever sump
- FRBHJ sump

See Bulletin PS-10-16.

**FRBHJC**  
**Cantilever Sump**

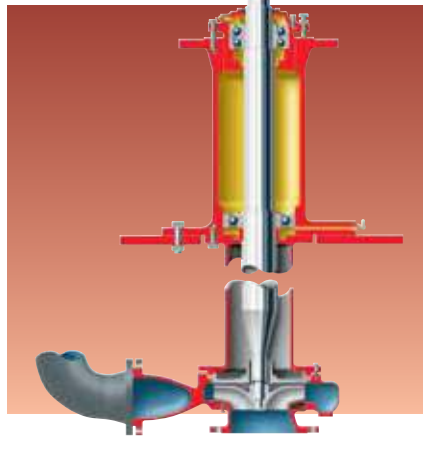

**Standards**

- Flowserve

**Operating Parameters**

- Flows to 2700 m<sup>3</sup>/h (12 000 gpm)
- Heads to 100 m (330 ft)
- Temperatures to 150°C (300°F)
- Speeds to 1780 rpm

**Features**

- True stiff shaft cantilever design, without bottom bearing or flushing water
- Steep head capacity
- Semi-open, full vane impeller with back pump-out vanes
- Direct coupled or V-belt driven
- Extra heavy-duty alloy steel shaft

**Related Configurations**

- FRBH heavy-duty paper stock and process
- FRBHJ vertical lineshaft sump

See Bulletin PS-10-16.

**MPT**  
**Self-Priming,**  
**Solids Handling**

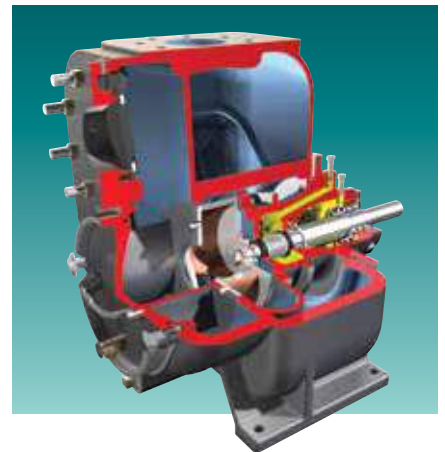

**Standards**

- Flowserve

**Operating Parameters**

- Flows to 600 m<sup>3</sup>/h (2650 gpm)
- Heads to 35 m (115 ft)
- Working pressures to 5 bar (72 psi)
- Temperatures to 75°C (165°F)
- Sizes 50 mm (2 in) to 200 mm (8 in)
- Solids to 75 mm (3 in) diameter

**Features**

- Two-vane, semi-open, solids handling impeller
- External impeller adjustment
- Abrasion-resistant, double mechanical seal
- Quick-disconnect cover plate
- Heavy-duty volute casing
- Replaceable seal housing
- Replaceable and reversible wear plate
- Solid one-piece flap valve
- Back pullout design
- Multiple drive options
- Extra large diameter shaft

See Bulletin PS-10-9.

**MF**  
**Solids Handling**

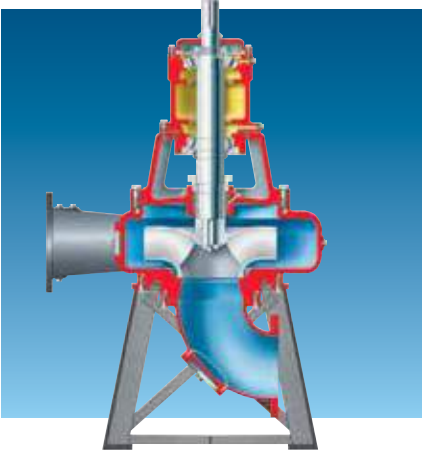

**Standards**  
• Flowserve

**Operating Parameters**  
• Flows to 2275 m<sup>3</sup>/h (10 000 gpm)  
• Heads to 90 m (300 ft)  
• Sizes to 400 mm (16 in)

**Features**  
• Variety of nozzle position options  
• Direct or independent motor mounting  
• Minimal shaft deflection  
• Oversized shaft and reduced overhang  
• Hardened chrome steel wear rings  
• Seal chamber accommodates packing or mechanical seals  
• Adjustable impeller clearance  
• Shaft sleeve options  
– 316 stainless steel  
– Hardened chrome steel  
• Bearing housing features  
– Ball or tapered roller bearings  
– Integral jacking bolts for wear ring adjustment  
– Accessible lubrication points

**Available Configurations**  
• MF horizontal, end suction  
• MFV vertical with motor on separate floor (shown)  
• MFC vertical with direct connected motor

See Bulletin PS-10-3.

**MN**  
**Large Capacity,  
Solids Handling**

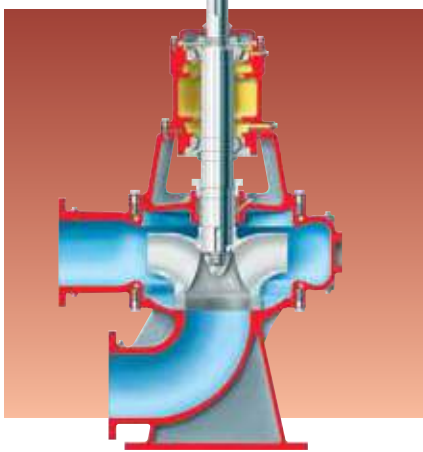

**Standards**  
• Flowserve

**Operating Parameters**  
• Flows to 45 500 m<sup>3</sup>/h (200 000 gpm)  
• Heads to 90 m (300 ft)  
• Sizes to 1800 mm (72 in)

**Features**  
• Variety of nozzle position options  
• Direct or independent motor mounting  
• Minimal shaft deflection  
• Oversized shaft and reduced overhang  
• Hardened chrome steel wear rings  
• Seal chamber accommodates packing or mechanical seals  
• Adjustable wear ring clearance  
• Shaft sleeve options  
– 316 stainless steel  
– Hardened chrome steel  
• Bearing housing features  
– Tapered roller bearings  
– Integral jacking bolts for wear ring adjustment  
– Accessible lubrication points

**Available Configurations**  
• MN horizontal, end suction  
• MNF vertical, bottom suction, direct connected motor  
• MNZ vertical, bottom suction, motor on separate floor  
• MNC vertical with base elbow, direct connected motor  
• MNV vertical with base elbow, motor on separate floor (shown)

See Bulletin PS-10-4.

**MSX**  
**Solids Handling,  
Submersible**

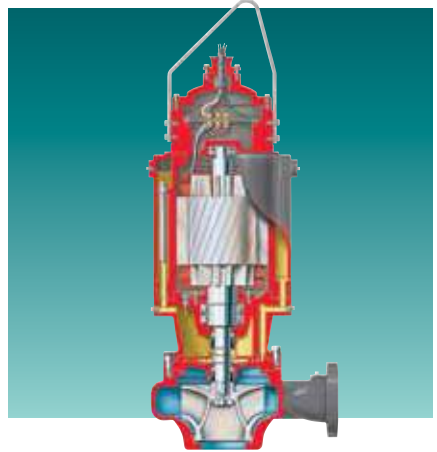

**Standards**  
• Flowserve

**Operating Parameters**  
• Flows to 4545 m<sup>3</sup>/h (20 000 gpm)  
• Heads to 90 m (300 ft)  
• Temperatures to 40°C (104°F)  
• Discharge sizes from 80 mm (3 in) to 500 mm (20 in)  
• Motor ratings to 224 kW (300 hp)  
• Solids handling to 80 mm (3 in) diameter spherical

**Features**  
• High-efficiency hydraulics  
• EPACT-rated motor  
• Spike-resistant windings  
• Class H insulation system  
• Dynamically balanced shaft and rotor  
• Mounting options  
– Wet-pit  
– Dry-pit  
– Transportable

**Available Configurations**  
• MSX Series 1: sizes from 75 mm (3 in) to 150 mm (6 in)  
• MSX Series 2/3: sizes to 500 mm (20 in)

See Bulletin PS-50-2.

## D800 Series Cast Iron

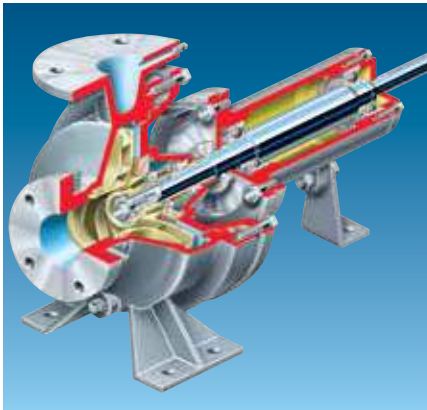

### Standards

- Flowserve

### Operating Parameters

- Flows to 340 m<sup>3</sup>/h (1500 gpm)
- Heads to 120 m (395 ft)
- Pressures to 15 bar (220 psi)
- Temperatures to 120°C (250°F)

### Features

- High-efficiency closed impeller
- Centerline discharge
- Sealed-for-life, pre-lubricated motor bearings with two-year minimum life
- Renewable wear rings and shaft sleeves
- Pre-set mechanical seal assembly
- Bell-type mechanical seal cover
- Standard NEMA C-face motor
- Back pullout design
- Threaded and flanged connections

### Available Configurations

- Type D-814 frame mounted
- Type D-824 close coupled
- Type D-834 vertical in-line

See Bulletin PS-10-6.

## MEN End Suction

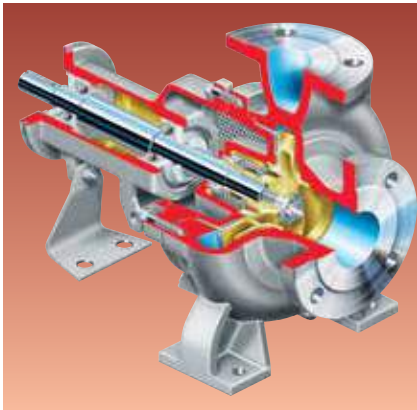

### Standards

- DIN 24255
- EN 733
- Flowserve

### Operating Parameters

- Flows to 800 m<sup>3</sup>/h (3520 gpm)
- Heads to 140 m (450 ft)
- Pressures to 16 bar (230 psi)
- Temperatures to 120°C (250°F)

### Features

- 33 sizes available
- Volute casing with top discharge
- Dynamically balanced, precision cast closed impeller with extended hub and machined shroud
- Impeller balance chamber and holes minimize axial thrust
- Open seal chamber with integral vortex breaking ribs
- Oversized stainless steel shaft
- Oversized bearings
- Standard case wear rings
- Back pullout design

### Related Configurations

- MEN-SP vertical cantilever sump
- MHP high-pressure
- MENBLOC close coupled
- ME horizontal high-capacity
- MEV vertical high-capacity

See Bulletin PS-10-2.

## MENBLOC Close Coupled



### Standards

- DIN 24255
- EN 733
- Flowserve

### Operating Parameters

- Flows to 340 m<sup>3</sup>/h (1500 gpm)
- Heads to 100 m (330 ft)
- Pressures to 16 bar (230 psi)
- Temperatures to 110°C (230°F)

### Features

- Compact, space-saving configuration
- End suction, top discharge, volute casing
- Dynamically balanced, precision cast high-efficiency closed impeller with extended hub
- Impeller balance chamber and holes minimize axial thrust
- Open seal chamber with integral vortex breaking ribs
- Oversized stainless steel shaft
- Oversized bearings
- Standard case wear rings
- Back pullout design
- Baseplate and coupling not required
- CE marked in Europe

### Related Configurations

- MEN horizontal end suction
- MEN-SP vertical cantilever sump
- MHP high-pressure
- ME horizontal high-capacity
- MEV vertical high-capacity

See Bulletin PS-10-2.

**ME**  
**End Suction**



- Standards**
- Flowsolve

- Operating Parameters**
- Flows to 3000 m<sup>3</sup>/h (13 200 gpm)
  - Heads to 90 m (295 ft)
  - Pressures from 4 bar (58 psi) to 16 bar (232 psi)
  - Temperatures to 120°C (250°F)

- Features**
- Single volute, end suction casing with tangential discharge
  - Back pullout design
  - Radial flow impeller shrouded, keyed on shaft
  - Impeller balance holes minimize axial thrust
  - Bearings
    - Radial ball bearing and roller bearings (depending on size)
    - Sealed-for-life for lower frames, rationalized with MEN sizes
    - Grease-lubricated for higher frames

- Related Configurations**
- MEV vertical, end suction
  - MEN horizontal, end suction (low-capacity)
  - MHP horizontal, end suction (low-capacity, high-pressure)
  - DS horizontal, end suction (high-capacity)

**DS**  
**Double Volute,**  
**End Suction**



- Standards**
- Flowsolve

- Operating Parameters**
- Flows to 5700 m<sup>3</sup>/h (25 000 gpm)
  - Heads to 110 m (350 ft)
  - Pressures to 27 bar (400 psi)
  - Temperatures to 120°C (250°F)

- Features**
- Double volute, end suction casing with centerline discharge
  - Mechanically balanced, radial flow impeller
  - Impeller balance holes minimize axial thrust
  - Seal chamber accommodates packing and multiple mechanical seal types
  - Back pullout design
  - Angular contact thrust bearing and parallel roller radial bearing
  - Grease lubrication standard; oil lubrication optional
  - Choice of materials from cast iron to super duplex

- Related Configurations**
- DSV vertical
  - Directional discharge (90° on the right or on the left)
  - Centerline mounted

**SMP**  
**Standard Motor**  
**End Suction**



- Standards**
- Flowsolve

- Operating Parameters**
- Flows to 135 m<sup>3</sup>/h (600 gpm)
  - Heads to 70 m (220 ft)
  - Pressures to 12 bar (175 psi)
  - Temperatures from -40°C (-40°F) to 120°C (250°F)

- Features**
- Glass reinforced polymer, high-efficiency, semi-open or closed flow impellers standard
  - Industry standard NEMA motors
  - Stainless steel, self-aligned mechanical seal
  - Back pullout design
  - Clamp-type mounting plate
  - Options
    - Cast iron, bronze or 316 stainless steel impellers
    - Stub shaft design

- Related Configurations**
- SMX non-metallic, standard motor pump
  - VSMP vertical, standard motor pump

See Bulletin PS-10-26.



**SMX**  
**Non-Metallic**  
**Standard Motor**

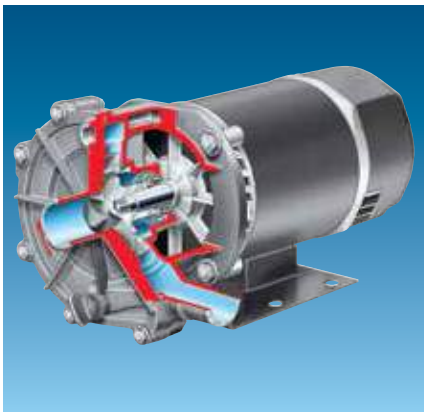

**Standards**  
 • Flowserve

**Operating Parameters**

- Flows to 25 m<sup>3</sup>/h (100 gpm)
- Heads to 20 m (60 ft)
- Pressures to 12 bar (175 psi)
- Temperatures to 80°C (180°F)

**Features**

- Polyphenylene sulfide (PPS) casing, adapter and impeller
- Standard NEMA 56J frame C-faced motor
- Stainless steel, self-aligned mechanical seal
- Back pullout design
- 40 mm (1.5 in) port size for hose connection

**Related Configurations**

- SMP standard motor pump
- VSMP vertical standard motor pump

See Bulletin PS-10-26.

**F-Line**  
**End Suction, Multistage**

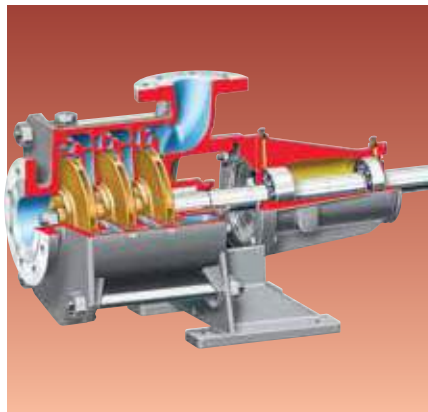

**Standards**  
 • Flowserve

**Operating Parameters**

- Flows to 500 m<sup>3</sup>/h (2200 gpm)
- Heads to 250 m (820 ft)
- Discharge pressures to 25 bar (365 psi)
- Temperatures to 105°C (220°F)

**Features**

- Modular design
  - 8 sizes
  - 15 hydraulics
  - 2 impeller types
- To 9 stages, depending on model and operating speed
- Sleeved shaft under sealing system
- Cast iron EN-GJL 250 pressure casings
- Cast iron EN-GJL 250 or NORYL<sup>®</sup> impellers, depending upon model
- Steel grade C 35 E shaft
- 13% chromium steel sleeve

**Available Configurations**

- FP horizontal, overhung impeller
- FM horizontal, close coupled
- FD vertical
- FS vertical, suspended shaft wet-pit
- FMD vertical, close coupled
- FAD vertical, rigid coupled

© NORYL is a registered trademark of General Electric Company.

**MVE**  
**End Suction**



**Standards**  
 • Flowserve

**Operating Parameters**

- Flows to 2700 m<sup>3</sup>/h (11 890 gpm)
- Heads to 15 m (50 ft)
- Pressures to 7 bar (100 psi)
- Temperatures to 100°C (212°F)

**Features**

- Single volute casing with end suction and side discharge; top discharge optional
- Mechanically balanced, mixed flow impeller
- Seal chamber accommodates packing and multiple mechanical seal types
- Back pullout design
- Standard angular contact radial and thrust bearings
- Standard grease lubrication; oil lubrication optional
- Choice of materials
  - Cast iron
  - Ni-Resist<sup>®</sup>
  - Bronze
  - Super duplex stainless steel

© Ni-Resist is a registered trademark of the International Nickel Co., Inc.

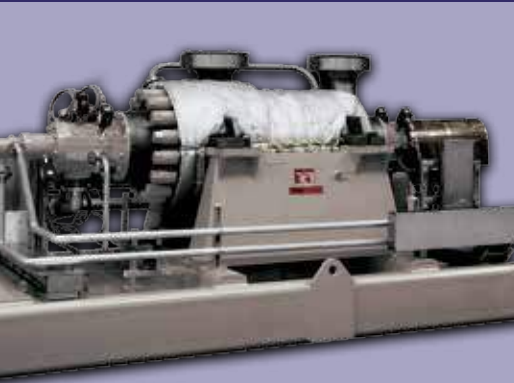

## Between Bearings Pumps

### Single Case — Axially Split — Single-Stage

LR	28
LNN	28
DVSH	28
LPN	29

### Single Case — Axially Split — Multistage

EC	30
UZDL	30
DMX	30

### Single Case — Radially Split — Single-Stage

HDX	31
HDX-TT	31
DVSR	31

### Single Case — Radially Split — Multistage

HED	32
HED-DS	32
WTB	32
WD	33
WDX	33
NM	33
WX	33
CSX	34
WXH	34

### Double Case

WXB	35
WXB-B	35
WNC	35
CSB	35
CHTA	36
HDB	36
HSB	36
BP	36
WCC	37
HDO	37
HSO	37
WIK	37
WIKO	37

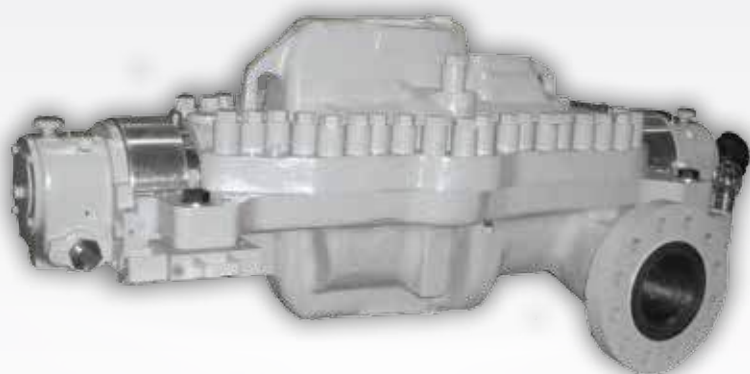

## LR Axially Split, Single-Stage

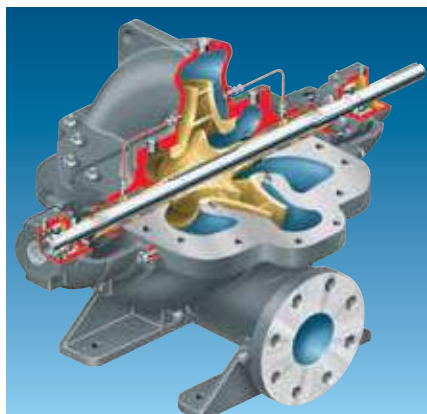

### Standards

- Flowsolve

### Operating Parameters

- Flows to 2000 m<sup>3</sup>/h (8800 gpm)
- Heads to 170 m (560 ft)
- Pressures to 21 bar (300 psi)
- Temperatures from -30°C (-20°F) to 150°C (300°F)

### Features

- Split-case design with lifting lugs
- Low NPSH double-suction impeller on many sizes
- Flat or raised face suction and discharge flanges to ANSI, DIN and ISO standards
- Oil- or grease-lubricated radial and thrust bearings
  - Single row, deep groove ball bearings or duplex thrust ball bearings
  - 100 000 hours typical L10 bearing life
- Seal chamber accommodates multiple seal types
- Standard case wear rings; optional serrated groove designs
- Optional impeller wear rings
- Available high-performance coatings

### Related Configurations

- LRV vertical, axially split, single-stage
- LLR axially split, two-stage

See Bulletin PS-20-3.

## LNN Axially Split, Double-Suction, Single-Stage

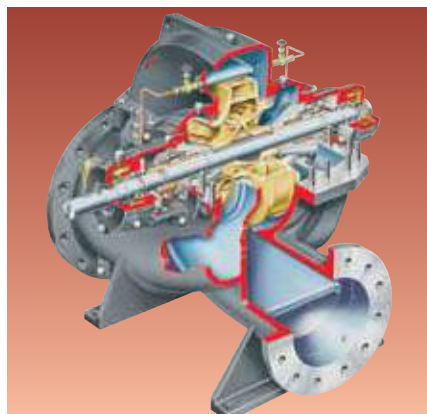

### Standards

- Flowsolve

### Operating Parameters

- Flows to 30 000 m<sup>3</sup>/h (132 000 gpm)
- Heads to 300 m (985 ft)
- Pressures to 40 bar (580 psi)
- Temperatures to 140°C (285°F)

### Features

- Heavy-duty, double volute casing with side suction and side discharge
- Flanges to ANSI, DIN and ISO standards
- Hydraulically balanced double-suction impeller
- Optimum axial and radial thrust balance
- Standard casing wear rings; optional impeller wear rings
- Seal chamber accommodates packing and multiple mechanical seal types
- 360° supported bearing housing
- Choice of bearings
  - Standard ball radial and ball thrust
  - Optional double row, angular contact thrust bearings
  - Optional sleeve bearings
- Grease lubrication standard; oil mist and bath optional
- Choice of materials

### Related Configurations

- LNNV vertical, single-stage
- LNNC single-stage, bottom suction
- LNE, LNS, LNST and LNGT axially split, single-stage

See Bulletin PS-20-1.

## DVSH (BB1) Axially Split, Double-Suction, Single-Stage

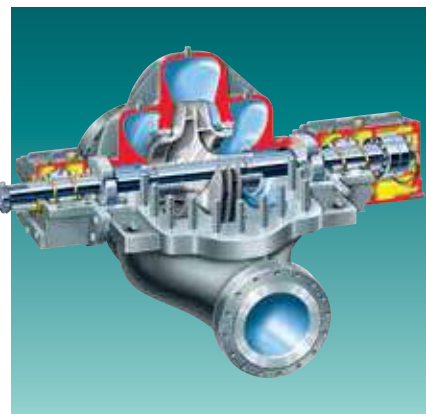

### Standards

- ISO 13709/API 610 (BB1), latest ed.

### Operating Parameters

- Flows to 12 000 m<sup>3</sup>/h (52 835 gpm)
- Heads to 565 m (1854 ft)
- Pressures to 150 bar (2175 psi)
- Temperatures to 204°C (400°F)
- Speeds to 6000 rpm

### Features

- Double volute casing
- Hydraulically balanced double-suction impeller
- ISO 21049/API 682 seal chambers accommodate multiple seal types
- Stiff shaft design
- Baseplate designs and pump packages engineered to contract requirements
- Choice of bearings
  - Ball radial and thrust
  - Sleeve radial and ball thrust
  - Sleeve radial and tilting pad thrust
- Choice of materials
  - Carbon steel
  - 12% chrome
  - Austenitic stainless steels
  - Duplex stainless steels

See Bulletin PS-20-2.

## **LPN (BB1)** **Axially Split, Double-** **Suction, Single-Stage**

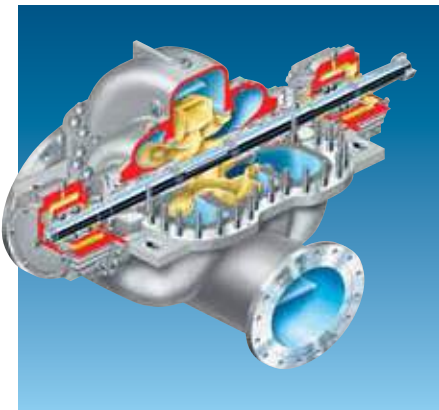

### **Standards**

- ISO 13709/API 610 (BB1), latest ed.

### **Operating Parameters**

- Flows to 15 000 m<sup>3</sup>/h (65 000 gpm)
- Heads to 250 m (820 ft)
- Pressures to 25 bar (365 psi); 50 bar (725 psi) with LPN-H model
- Temperatures from -80°C (-110°F) to 204°C (400°F)

### **Features**

- Double volute, near-centerline supported casing
- ASME (ANSI) B16.5 Class 150 or Class 300 raised face flanges
- Confined gasket design
- Hydraulically balanced double-suction impeller
- ISO 21049/API 682 seal chambers
- Baseplate designs and pump packages engineered to contract
- Heavy-duty, bracketed, 180° supported carbon steel bearing housing
- Standard non-contacting labyrinth seals
- Choice of bearings
  - Ball radial and ball thrust with oil flinger system
  - Split sleeve radial and ball thrust with ring oil system
  - Split sleeve radial and tilting pad thrust with pressure lubrication

### **Other Configurations**

- LPN-H high-pressure, double-suction
- LPN-V vertical in-line

See Bulletin PS-20-5.

## EC Axially Split, Multistage



### Standards

- Flowsolve

### Operating Parameters

- Flows to 2340 m<sup>3</sup>/h (10 300 gpm)
- Heads to 650 m (2130 ft)
- Pressures to 88 bar (1300 psi)
- Temperatures from -30°C (-20°F) to 150°C (300°F)

### Features

- Horizontally split case with integral mounting feet
- In-line mounted impellers
- Rotating assembly balanced as a unit
- Case wear rings standard at impeller eye
- Diaphragm rings standard at impeller back shroud
- Shaft protected by interstage and packing sleeves
- Seal chambers accommodate packing or mechanical seals
- Double-row antifriction radial and thrust bearings
- Grease lubrication

## UZDL (BB1) Axially Split, Two-Stage

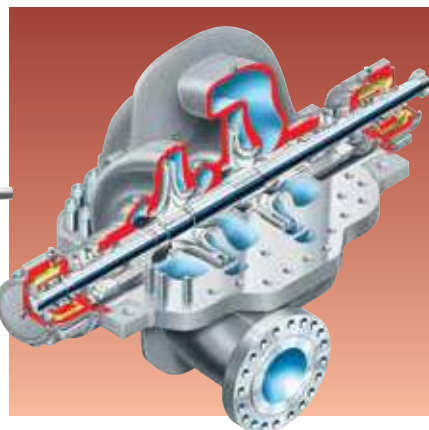

### Standards

- ISO 13709/API 610 (BB1), latest ed.

### Operating Parameters

- Flows to 2950 m<sup>3</sup>/h (13 000 gpm)
- Heads to 685 m (2250 ft)
- Pressures to 64 bar (910 psi)
- Temperatures to 204°C (400°F)
- Speeds to 2000 rpm

### Features

- Double volute hydraulic passages
- ISO 21049/API 682 seal chambers
- Shaft options
  - Double extension for connection to auxiliary pumps or hydraulic turbines
  - Special shaft end machining for hydraulic fitted couplings
- Baseplate designs and pump packages engineered to contract
- Dynamic balancing and TIR verifications on assembled rotors
- Choice of bearings
  - Ball radial and thrust
  - Sleeve radial and ball thrust
  - Sleeve radial and tilting pad thrust
  - Tilting pad radial and tilting pad thrust
- Choice of materials
  - Carbon steel
  - 12% chrome
  - Austenitic stainless steels
  - Duplex stainless steels
  - Monel®

See Bulletin PS-30-2.

## DMX (BB3) Axially Split, Multistage

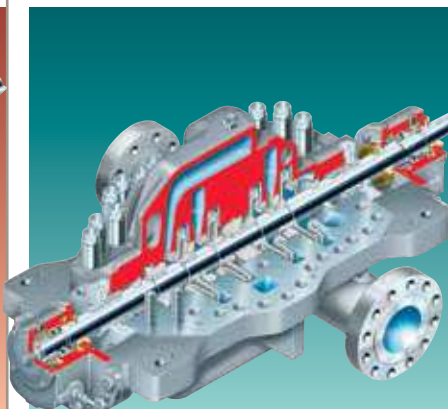

### Standards

- ISO 13709/API 610 (BB3), latest ed.

### Operating Parameters

- Flows to 2950 m<sup>3</sup>/h (13 000 gpm)
- Heads to 2130 m (7000 ft)
- Pressures to 275 bar (4000 psi)
- Temperatures to 204°C (400°F)
- Speeds to 6000 rpm

### Features

- Double volute hydraulic passages
- Renewable case and impeller wear rings
- ISO 21049/API 682 seal chambers
- Axially split center bushing
- Shaft options
  - Double extension for connection to auxiliary pumps or hydraulic turbines
  - Special shaft end machining for hydraulic fitted couplings
- Interstage take-off option
- Baseplate designs and pump packages engineered to contract
- Dynamic balancing and TIR verifications on assembled rotors
- Choice of bearings
  - Ball radial and thrust
  - Sleeve radial and ball thrust
  - Sleeve radial and tilting pad thrust
- Choice of bearing lubrication systems
- Choice of bearing cooling systems
- Choice of materials

See Bulletin PS-30-3.

**HDX (BB2)**  
**Radially Split, Double-Suction, Single-Stage**

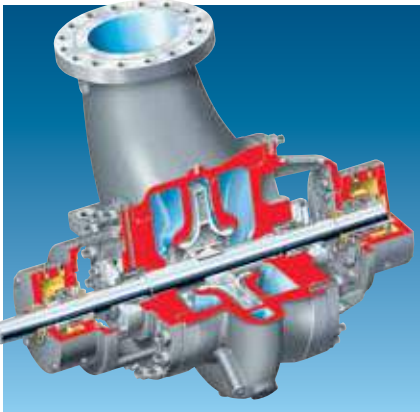

**Standards**

- ISO 13709/API 610 (BB2), latest ed.

**Operating Parameters**

- Flows to 4100 m<sup>3</sup>/h (18 000 gpm)
- Heads to 450 m (1500 ft)
- Pressures to 42 bar (610 psi); 100 bar (1450 psi) with HDX-H model
- Temperatures to 450°C (842°F)

**Features**

- Double volute, centerline supported, self-venting casing
- ASME (ANSI) B16.5 Class 300 flanges; optional Class 600 and 900 flanges
- Dynamically balanced, double-suction impeller
- Stiff shaft design
- ISO 21049/API 682 seal chambers
- Standard dual single-row, back-to-back mounted, angular contact thrust bearing
- Bearing options
  - Sleeve radial and ball thrust
  - Sleeve radial and tilting pad thrust
  - Lubrication systems available
- 360° supported bearing housing
- Double case covers

**Related Configurations**

- HDX-H high-pressure, radially split, double-suction
- In-line side nozzles
- Same-side nozzles (90° rotated)

See Bulletin PS-20-4.

**HDX-TT (BB2)**  
**Radially Split, Power Recovery Turbine**

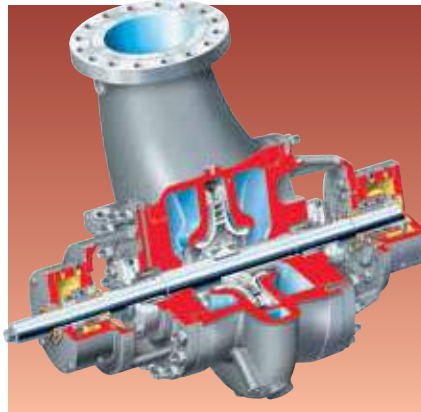

**Standards**

- ISO 13709/API 610 (BB2), latest ed.

**Operating Parameters**

- Flows to 4100 m<sup>3</sup>/h (18 000 gpm)
- Heads to 760 m (2500 ft)
- Pressures to 100 bar (1450 psi)
- Temperatures to 450°C (842°F)

**Features**

- Double volute, centerline supported, self-venting casing with diffuser
- ASME (ANSI) B16.5 Class 300 flanges; optional Class 600 and 900 flanges
- Dynamically balanced, double-suction, radial inflow turbine runner
- Stiff shaft design
- ISO 21049/API 682 seal chambers
- Standard dual single-row, back-to-back mounted, angular contact thrust bearing
- Bearing options
  - Sleeve radial and ball thrust
  - Sleeve radial and tilting pad thrust
  - Lubrication systems available
- 360° supported bearing housing
- Double case covers

**Other Configurations**

- High-pressure
- In-line side nozzles
- Side-side nozzles (90° rotated)

**DVSR (BB2)**  
**Radially Split, Volute Casing, Single-Stage**

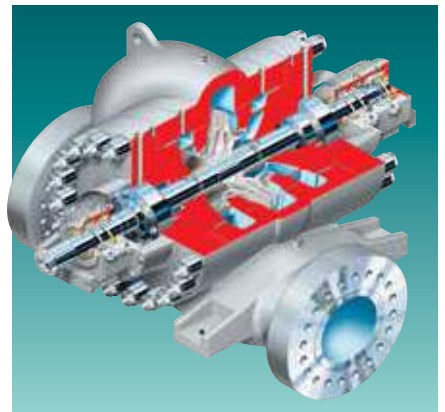

**Standards**

- ISO 13709/API 610 (BB2), latest ed.

**Operating Parameters**

- Flows to 3635 m<sup>3</sup>/h (16 000 gpm)
- Heads to 250 m (820 ft)
- Pressures to 260 bar (3750 psi)
- Temperatures to 204°C (400°F)
- Speeds to 4000 rpm

**Features**

- Double volute casing
- Hydraulically balanced double-suction impeller
- Staggered vane impellers
- Stiff shaft design
- ISO 21049/API 682 seal chambers
- Baseplate designs and pump packages engineered to contract
- Choice of bearings
  - Sleeve radial and ball thrust
  - Sleeve radial and tilting pad thrust
  - Tilting pad radial and tilting pad thrust
- Choice of materials
  - Carbon steel
  - 12% chrome

## HED (BB2) Radially Split, Two-Stage



### Standards

- ISO 13709/API 610 (BB2), latest ed.

### Operating Parameters

- Flows to 1000 m<sup>3</sup>/h (4400 gpm)
- Heads to 650 m (2100 ft)
- Pressures to 120 bar (1750 psi)
- Temperatures to 450°C (842°F)

### Features

- Heavy-duty, double volute casing with 180° staggered volutes
- Top-top nozzle configuration
- ISO 21049/API 682 seal chambers
- Dynamic balancing and TIR verifications on assembled rotating element
- Baseplate designs and pump packages engineered to contract
- Choice of bearings
  - Ball radial and thrust
  - Sleeve radial and ball thrust
  - Sleeve radial and tilting pad thrust
- Choice of materials
  - Carbon steel
  - 12% chrome
  - Austenitic stainless steel
  - Duplex stainless steel
  - Monel lining

### Other Configurations

- HED-DS radially split, double-suction, two-stage
- In-line side nozzles
- Same-side nozzles
- High-pressure

See Bulletin PS-30-4.

## HED-DS (BB2) Radially Split, Double-Suction, Two-Stage

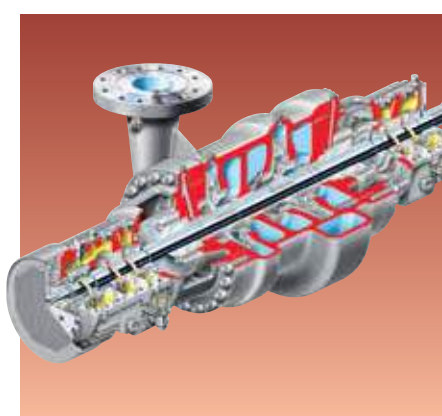

### Standards

- ISO 13709/API 610 (BB2), latest ed.

### Operating Parameters

- Flows to 2500 m<sup>3</sup>/h (11 000 gpm)
- Heads to 750 m (2460 ft)
- Pressures to 120 bar (1750 psi)
- Temperatures to 450°C (842°F)

### Features

- Double-suction, first-stage impeller
- Heavy-duty, double volute casing with 180° staggered volutes
- Top-top nozzle configuration
- ISO 21049/API 682 seal chambers
- Dynamic balancing and TIR verifications on assembled rotating element
- Baseplate designs and pump packages engineered to contract
- Choice of bearings
  - Ball radial and thrust
  - Sleeve radial and ball thrust
  - Sleeve radial and tilting pad thrust
- Choice of materials
  - Carbon steel
  - 12% chrome
  - Austenitic stainless steel
  - Duplex stainless steel
  - Monel lining

### Other Configurations

- HED radially split, two-stage
- In-line side nozzles
- Same-side nozzles
- High-pressure

See Bulletin PS-30-4.

## WTB (BB2) Radially Split, Double-Suction, Three-Stage

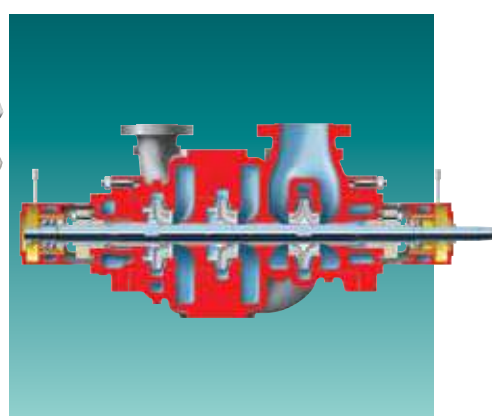

### Standards

- ISO 13709/API 610 (BB2), latest ed.

### Operating Parameters

- Flows to 1400 m<sup>3</sup>/h (6165 gpm)
- Heads to 1100 m (3610 ft)
- Pressures to 108 bar (1565 psi)
- Temperatures to 430°C (800°F)
- Speeds to 3600 rpm

### Features

- Meets intent of key ISO/API requirements
- Heavy-duty, centerline supported, double volute casing with integral crossover
- ASME (ANSI) B16.5 Class 300 flanges; Class 600 and 900 flanges optional
- Dynamically balanced, double-suction first-stage impeller; single-suction on smallest three-stage only
- Balance holes on second- and third-stage impellers
- ISO 21049/API 682 seal chambers
- 360° supported bearing housing
- Choice of bearings
  - Sleeve radial and ball thrust
  - Sleeve radial and tilting pad thrust
  - Dual, single row, angular contact antifriction thrust bearings installed back-to-back and single row, deep groove antifriction radial bearing

### Available Configurations

- WTB three-stage, double-suction
- WTB two-stage, single-suction
- WTB two-stage, double-suction

See Bulletin PS-30-14.



**WD and WDX**  
**Radially Split, Multistage,**  
**Ring Section**

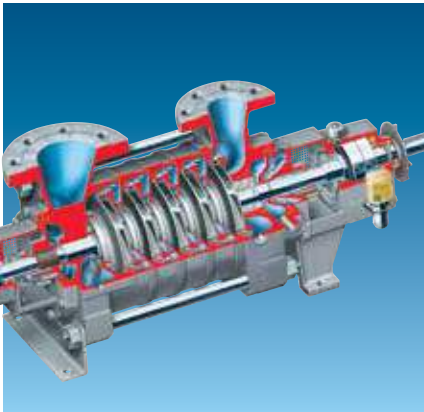

**Standards**  
 • Flowserve

**Operating Parameters**

- Flows to 190 m<sup>3</sup>/h (800 gpm)
- Heads to 700 m (2300 ft)
- Pressures to 75 bar (1090 psi)
- Temperatures to 210°C (410°F)

**Features**

- Multivane diffusers
- Identical radially split ring section sets
- O-ring interstage sealing arrangement
- Deep groove ball bearing design
- Angular contact, double row thrust bearing
- 360° machine registered bearing housing fits
- Dynamically balanced, precision machined enclosed impellers
- Packing or mechanical sealing
- Options
  - Multiple flange orientations
  - End suction design with product lubricated sleeve bearing
  - Radial suction design with product lubricated sleeve bearing
  - Inducer

**NM**  
**Radially Split,**  
**Multistage, Ring Section**

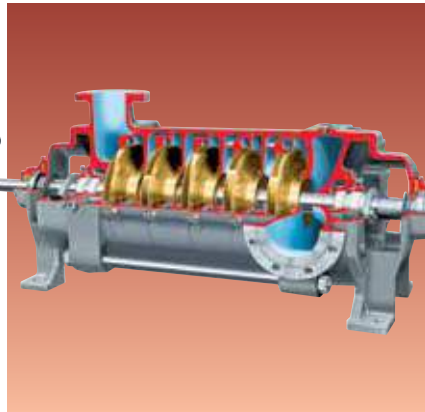

**Standards**  
 • Flowserve

**Operating Parameters**

- Flows to 3000 m<sup>3</sup>/h (13 210 gpm)
- Heads to 500 m (1640 ft)
- Pressures to 60 bar (870 psi)
- Temperatures to 140°C (285°F)

**Features**

- Modular design
  - 15 sizes
  - 22 hydraulics
- Low NPSH suction volute design
- Machined impeller shrouds for increased efficiency
- Impeller balance holes minimize axial thrust
- Shrouded diffusers with return guide vanes minimize radial thrust
- Removable seal housings accommodate gland packing and mechanical seals
- Standard cast iron construction; high alloy construction available

**Other Configurations**

- NMV vertical, multistage ring section
- NMD vertical, multistage ring section
- NM-S vertical, suspended shaft wet-pit
- NMAD vertical, rigid shaft coupling

**WX**  
**Radially Split,**  
**Multistage, Ring Section**

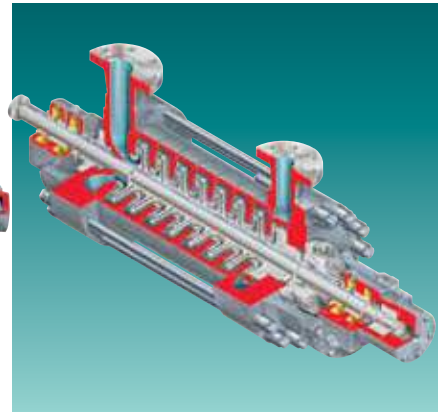

**Standards**  
 • Flowserve

**Operating Parameters**

- Flows to 300 m<sup>3</sup>/h (1320 gpm)
- Heads to 1200 m (3940 ft)
- Pressures to 150 bar (2175 psi)
- Temperatures from -50°C (-58°F) to 204°C (400°F)

**Features**

- Separate cast diffusers and channel rings
- Centerline mounted, self-venting casing
- Top-top nozzles
- Interstage O-ring seals
- Individual impeller balance
- Precision-fit rotor
- Optional inducer for low NPSHR

**CSX**  
**Radially Split,  
 Multistage, Ring Section**

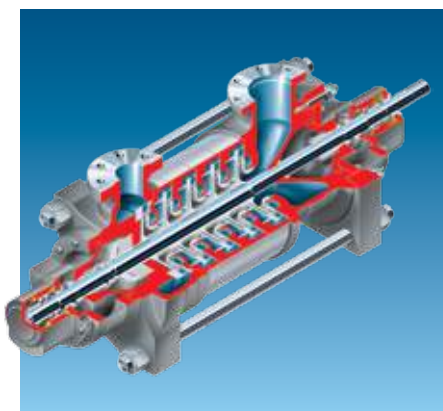

**Standards**

- Flowsolve

**Operating Parameters**

- Flows to 600 m<sup>3</sup>/h (2650 gpm)
- Heads to 900 m (2950 ft)
- Pressures to 100 bar (1450 psi)

**Features**

- Multistage, ring section, foot mounted design
- Dynamically balanced, precision cast, high-efficiency impellers
- Renewable case wear rings
- Precision cast diffuser and channel rings
- Flexible nozzle orientation
- Self-compensating balancing device
- Symmetrical suction and discharge heads
- Generously proportioned shaft
- Choice of bearings
  - Ball radial and thrust
  - Sleeve radial and ball thrust
  - Sleeve radial and tilting pad thrust
- Corrosion-resistant construction with options including duplex stainless steels, super duplex stainless steels, and proprietary Alloy 885

See Bulletin PS-30-15.

**WXH**  
**Radially Split, Multistage,  
 High-Pressure,  
 Ring Section**

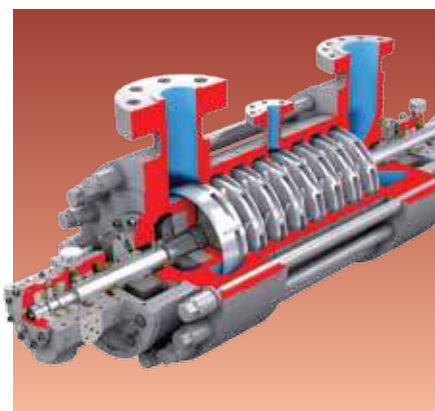

**Standards**

- Flowsolve

**Operating Parameters**

- Flows to 900 m<sup>3</sup>/h (4000 gpm)
- Heads to 2650 m (8700 ft)
- Pressures to 310 bar (4500 psi)
- Temperatures to 250°C (480°F)

**Features**

- Cast suction and discharge heads with integral nozzles
- Single- or double-suction, first-stage impeller designs
- Investment cast diffusers and return channel hydraulic passages
- Compression interstage O-ring
- Separate, high-strength, sub-base
- Replaceable stationary wear parts mounted in the diffusers
- Standard flanged balance drum with serrated running clearances; optional straight balance drum
- Seal chamber accepts single, double and tandem mechanical seals
- Large diameter shaft with staggered impeller and balancing device keyways
- No pre-warming required
- Chrome steel nozzles
- Choice of bearings
  - Ball radial and thrust
  - Sleeve radial and ball thrust
  - Sleeve radial and tilting pad thrust

See Bulletin PS-30-1.

**WXB and WXB-B  
Diffuser Casing,  
Multistage, Process Barrel**

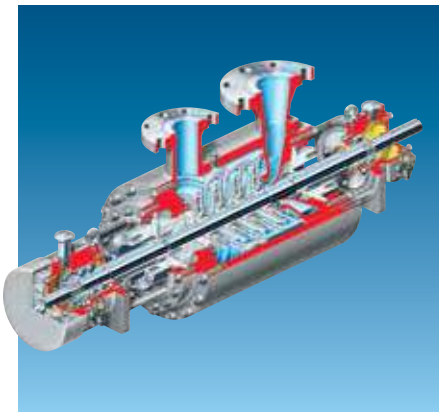

**Standards**

- ASME Section VIII

**Operating Parameters**

- Flows to 300 m<sup>3</sup>/h (1320 gpm)
- Heads to 1200 m (3940 ft)
- Pressures to 150 bar (2175 psi)
- Temperatures to 200°C (390°F)

**Features**

- Diffuser case construction
- Removeable cartridge inner case subassembly
- Large eye first-stage impeller
- Low-flow, high-head Barske impeller on WXB-B
- Proprietary balancing device
- Sleeve mounted deep groove radial and back-to-back mounted angular contact bearings
- High-capacity, antifriction thrust bearing
- Bearing lubrication system with oil bath, constant level oiler and sight glass
- Renewable casing and impeller rings
- High shaft diameter to bearing span ratio
- Options
  - Hydrodynamic sleeve radial bearings
  - Thrust bearing cooling system (air)
  - Labyrinth end seals

**Available Configurations**

- WXB: standard hydraulics
- WXB-B: low-flow, high-head hydraulics

See Bulletins PS-30-6 and PSS-30-6.1.

**WNC  
Diffuser Casing,  
Multistage, Utility Barrel**

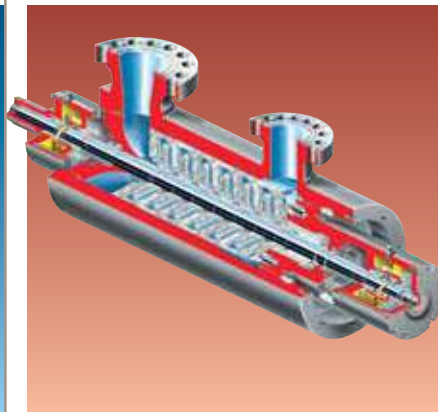

**Standards**

- ASME Section VIII

**Operating Parameters**

- Flows to 1400 m<sup>3</sup>/h (6200 gpm)
- Pressures to 350 bar (5075 psi)
- Temperatures to 200°C (390°F)

**Features**

- Diffuser case construction
- Shear ring design
- High-strength forged steel barrel; alloy barrels available
- Removeable cartridge inner case subassembly
- Shear ring barrel closing system
- Single- or double-suction, first-stage impeller
- Standard antifriction or sleeve radial bearings
- High-capacity antifriction thrust bearing; tilting pad thrust bearing available
- Renewable casing rings
- Straight balance drum forged from hardened stainless steel
- Chrome-plated shafting under journal bearings
- Ground forged steel shafting

**Related Configurations**

- WNC-HP high-pressure, diffuser casing, multistage, utility barrel

See Bulletin PS-30-12.

**CSB  
Diffuser Casing,  
Multistage, Utility Barrel**

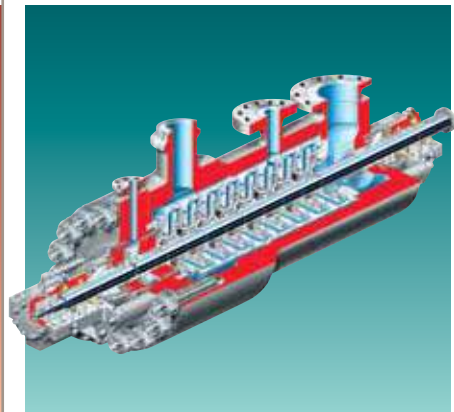

**Standards**

- ASME Section VIII

**Operating Parameters**

- Flows to 1500 m<sup>3</sup>/h (6600 gpm)
- Discharge pressures to 300 bar (4350 psi)
- Temperatures to 250°C (480°F)
- Speeds to 8000 rpm

**Features**

- Internal casing with segmented stage elements
- Diffuser guide-vane construction
- Precision cast in-line impellers of high-quality chrome steel
- Heavy-duty barrel with forged steel discharge cover
- Fully enclosed or shrouded precision cast diffusers on high-energy applications
- Tilt pad thrust and tri-land radial bearings
- Renewable casing rings and sleeves
- Flanged balance drum forged from hardened stainless steel; straight drum optional
- Chrome-plated shafting under journal bearings
- Ground forged steel shafting

See Bulletin PS-30-12.

**CHTA**  
**Diffuser Casing,**  
**Multistage, Utility Barrel**

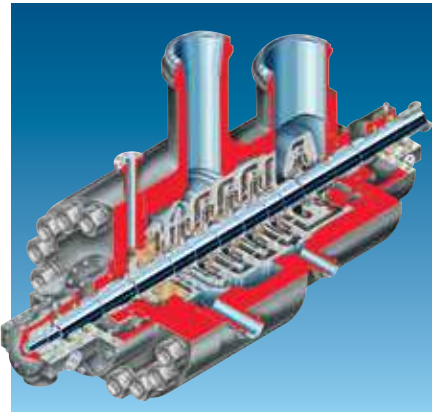

**Standards**

- ASME Section VIII

**Operating Parameters**

- Flows to 5220 m<sup>3</sup>/h (23 000 gpm)
- Heads to 4270 m (14 000 ft)
- Discharge pressures to 517 bar (7500 psi)
- Temperatures to 250°C (480°F)
- Speeds to 6000 rpm

**Features**

- Internal casing with segmented stage elements
- Diffuser guide-vane construction
- Precision cast in-line impellers of high-quality chrome steel
- Heavy-duty barrel with forged steel discharge cover
- Fully enclosed or shrouded precision cast diffusers on high-energy applications
- Balance drum and sleeve made from hardened stainless steel forgings
- Tilt pad thrust and tri-land radial bearings
- Serrated running fits
- Renewable casing rings and sleeves
- Flanged balance drum design
- Chrome-plated shafting under journal bearings
- Ground forged steel shafting

See Bulletin PS-30-13.

**HDB and HSB**  
**Volute Casing,**  
**Multistage, Utility Barrel**

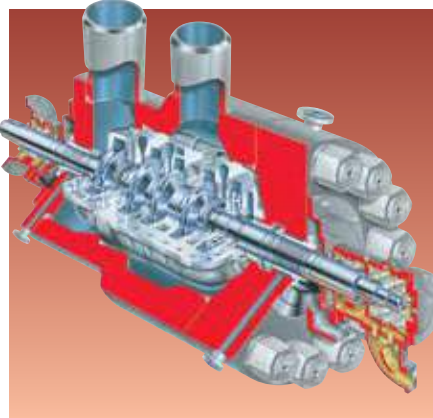

**Standards**

- ASME Section VIII

**Operating Parameters**

- Flows to 4000 m<sup>3</sup>/h (17 610 gpm)
- Heads to 4300 m (14 000 ft)
- Discharge pressures to 450 bar (6525 psi)
- Temperatures to 425°C (800°F)
- Speeds to 9000 rpm

**Features**

- Axially split inner casing
- Double volute design with symmetrical upper and lower halves
- Opposed impeller design
- Volute and impellers are cast of high-quality chrome steel
- Heavy-duty forged steel barrel and discharge cover
- Individually mounted and secured impellers
- Dynamic balancing and TIR verifications on assembled rotor
- Minimal pressure breakdowns across running clearances
- Sleeve radial and tilting pad thrust bearings
- Baseplate designs and pump packages engineered to contract requirements

See Bulletin PS-30-12.

**BP (BB5)**  
**Diffuser Casing,**  
**Multistage, Process Barrel**

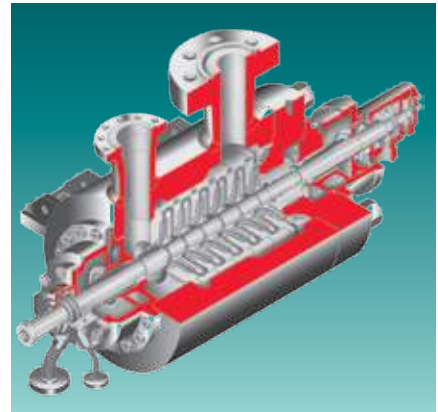

**Standards**

- ISO 13709/API 610 (BB5), latest ed.

**Operating Parameters**

- Flows to 1050 m<sup>3</sup>/h (4620 gpm)
- Heads to 3500 m (11 480 ft)
- Discharge pressures to 295 bar (4260 psi)
- Temperatures to 425°C (800°F)
- Speeds to 6000 rpm

**Features**

- Diffuser guide-vane inner casing with segmented stage elements
- Inner casing bolted head at one end
- Heavy-duty barrel with forged steel discharge cover
- Multi-vane diffuser and channel ring design
- Precision cast diffusers
- Precision cast keyed impellers; optional shrink-fit impellers for high-speed or high-temperature service
- Single- or double-suction, first-stage impeller
- Straight style balance drum
- Forged shaft; optional stepped shaft for high-speed or high-temperature service
- Choice of bearings
  - Ball radial and ball thrust with oil flinger lubrication system
  - Sleeve radial and tilting pad thrust bearings with pressure lubrication system

See Bulletin PS-30-11.

**WCC (BB5)  
Diffuser Casing,  
Multistage, Process Barrel**

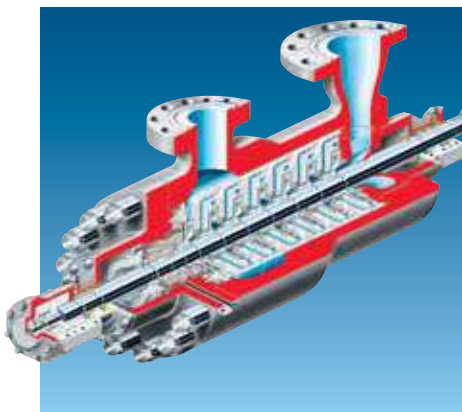

**Standards**

- ISO 13709/API 610 (BB5), latest ed.

**Operating Parameters**

- Flows to 1000 m<sup>3</sup>/h (4400 gpm)
- Heads to 2800 m (9200 ft)
- Discharge pressures to 275 bar (3987 psi)
- Temperatures to 425°C (800°F)
- Speeds to 3580 rpm; 6000 rpm with high-speed option

**Features**

- Internal casing with segmented stage elements
- Diffuser guide-vane construction
- Multi-vane, diffuser-channel ring collectors
- Precision cast chrome steel in-line impellers
- Single- or double-suction, first-stage impeller
- Heavy-duty barrel with discharge cover
- Removable cartridge inner case subassembly
- Straight or flanged balance drum with serrated running surfaces
- Tilt pad thrust and heavy-duty journal bearings
- Force feed lubricated bearings
- Precision-ground forged steel shafting

See Bulletin PS-30-7.

**HDO and HSO (BB5)  
Volute Casing, Multistage,  
Process Barrel**

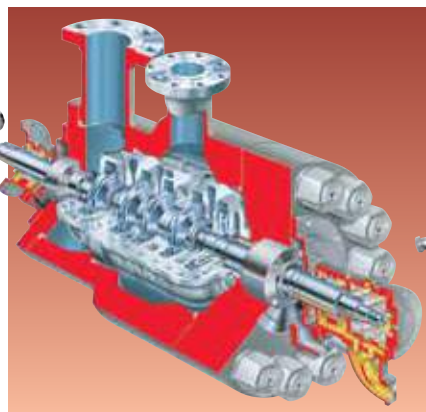

**Standards**

- ISO 13709/API 610 (BB5), latest ed.

**Operating Parameters**

- Flows to 4000 m<sup>3</sup>/h (17 610 gpm)
- Heads to 5365 m (16 000 ft)
- Discharge pressures to 450 bar (6525 psi)
- Temperatures to 425°C (800°F)
- Speeds to 9000 rpm

**Features**

- Axially split inner casing
- Double volute design with symmetrical upper and lower halves
- Opposed impeller design
- Heavy-duty forged steel barrel and discharge cover
- Individually mounted and secured impellers
- Dynamic balancing and TIR verifications on assembled rotor
- Sleeve radial and tilting pad thrust bearings
- Baseplate designs and pump packages engineered to contract requirements
- Metallurgies per ISO 13709/API 610

**Other Configurations**

- Coke crusher (for most sizes)

See Bulletin PS-30-8.

**WIK and WIKO (BB5)  
Diffuser Casing,  
Multistage, Process Barrel**

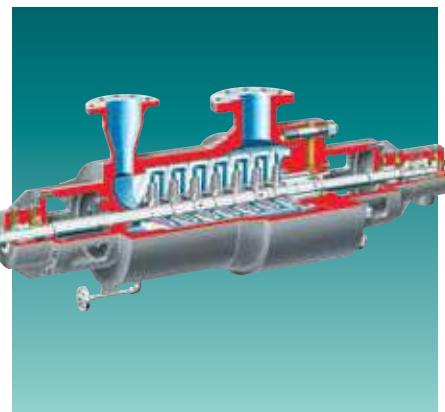

**Standards**

- ISO 13709/API 610 (BB5), latest ed.

**Operating Parameters**

- Flows to 4000 m<sup>3</sup>/h (17 610 gpm)
- Heads to 7000 m (23 000 ft)
- Discharge pressures to 650 bar (9425 psi)
- Temperatures to 450°C (842°F)
- Speeds to 13 000 rpm

**Features**

- Radially split inner casings
- Multi-vane diffuser and channel ring design
- Tandem or imposed impellers
- Inner casing with a bolted head at one end
  - Optional cartridge element design
  - Optional shear ring design
- Heavy-duty forged steel barrel casing and discharge head
- Precision cast and milled diffusers
- Precision cast impellers
- Shrink-fit and double-keyed impellers
- Straight balance drum
- Tilt pad thrust and sleeve radial bearings
- Large diameter shaft stepped at each impeller and balance drum
- NEMA taper shaft extension

**Available Configurations**

- WIK: tandem impellers
- WIKO: opposed impellers
- Coke crusher (for most sizes)

See Bulletin PS-30-9.



**Vertical Pumps****Wet-Pit**

WUJ	40
VTP	40
QL	40
QLQ	40
VCT	41
AFV	41
CVP	41

**Double Case**

QLC	42
QLQC	42
VPC	42
WUC	42
APKD	43

**Submersible**

Pleuger SUBM	44
Byron Jackson SUBM	44
MSX	44

**Slurry and Solids Handling**

MVX	45
MFV	45
MNV	45
FRBHJC	46
MJ	46
MJC	46
RJ	46
RJC	46
Terra-Titan™	47
MSX	47
Drain-Titan™	47

**Sump**

CPXV Chemical Sump	48
ESP3 Chemical Sump	48
PolyChem VGRP	48
Drain-Titan	49
VSMP	49
ECPJ	49



## WUJ (VS1) Vertical Lineshaft, Multistage

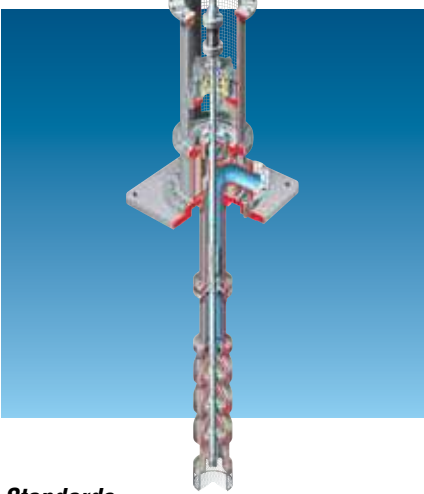

### Standards

- ISO 13709/API 610 (VS1), latest ed.
- ASME Sections VIII and IX
- Directive 94/9/EC (ATEX 100)

### Operating Parameters

- Flows to 3000 m<sup>3</sup>/h (13 200 gpm)
- Heads to 2000 m (6560 ft)
- Pressures to 200 bar (2900 psi)
- Temperatures from -200°C (-328°F) to 350°C (660°F)

### Features

- Radial or mixed flow hydraulics
- Multivane diffuser design
- Optional axial thrust tilting pad bearing configuration
- Stiff shaft design
- ISO 21049/API 682 seal chamber accommodates multiple seal types
- Flanged spacer coupling
- Screen-type, non-sparking coupling guard
- Casing and impeller wear rings
- Centerline aligned and flanged columns
- Reinforced motor stand
- Optional inducer

### Related Configurations

- WUC (VS6) double case, multistage

See Bulletin PS-40-8.

## VTP Vertical Turbine

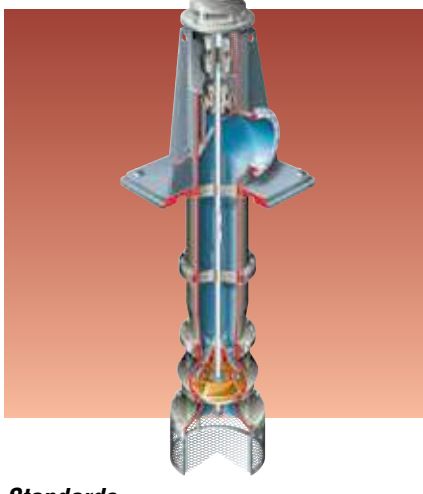

### Standards

- Flowserve

### Operating Parameters

- Flows to 13 600 m<sup>3</sup>/h (60 000 gpm)
- Heads to 700 m (2300 ft)
- Pressures to 100 bar (1450 psi)
- Temperatures from -45°C (-50°F) to 300°C (570°F)
- Sizes from 150 mm (6 in) to 1375 mm (54 in)
- Settings to 365 m (1200 ft)

### Features

- Above- or below-grade discharge
- Enclosed or semi-open impellers
- Open or enclosed lineshaft construction
- Product or enclosed oil lubrication
- Flanged or threaded column pipe
- High-pressure stuffing box
- Rigid, adjustable coupling
- Drive options
  - Hollow or solid shaft motor
  - Dry or submersible electric motors
  - Variable speed drives
  - Engine with right angle gear
  - Steam turbine
- Options
  - Thrust-balanced impeller
  - O-ring bowl
  - Adjustable flanged coupling

### Related Configurations

- VTP molten salt design
- VPC vertical turbine, double case

See Bulletin PS-40-7.

## QL and QLQ Vertical, Double-Suction, Double Volute

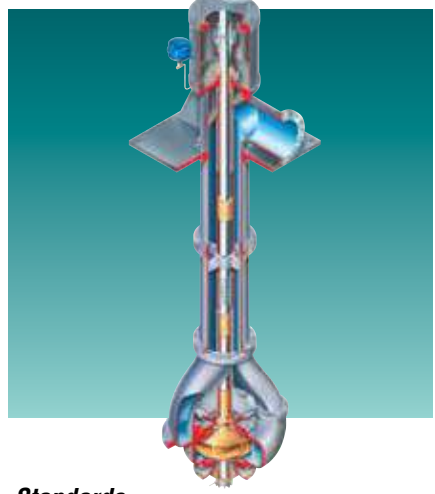

### Standards

- Flowserve
- ASME Sections VIII and IX

### Operating Parameters

- Flows to 25 000 m<sup>3</sup>/h (110 000 gpm)
- Heads to 500 m (1640 ft)
- Pressures to 70 bar (1015 psi)
- Temperatures to 204°C (400°F)
- Column sizes to 1500 mm (60 in)

### Features

- Heavy-wall double volute casing
- Double-suction, first-stage impeller
- Open lineshaft standard; enclosed lineshaft optional
- Heavy-duty discharge head
- Sealed-for-life bottom bearing
- Options
  - ISO 13709/API 610 (VS2), latest ed., and Directive 94/9/EC (ATEX 100) compliant configurations
  - Vertical solid shaft or hollow shaft motors with thrust bearing
  - Oiler and solenoid switch for pump bearing lubrication
  - Water, grease or oil lubricant
  - Lubrication lines for bottom bearing
  - Antifriction (self-lubricated) or tilting pad axial thrust bearing assembly
  - Rigid, adjustable spacer coupling

### Available Configurations

- QL single-stage
- QLQ multistage
- QLC double case, single-stage
- QLQC double case, multistage

See Bulletin PS-40-4.



**VCT**  
**Vertical, Mixed Flow**



**Standards**

- Hydraulic Institute
- AWWA

**Operating Parameters**

- Flows to 181 700 m<sup>3</sup>/h (800 000 gpm)
- Heads to 110 m (350 ft)
- Sizes from 1200 mm (48 in) to 3380 mm (133 in)

**Features**

- Five-mitered elbow discharge head with above- or below-grade discharge
- Pullout or non-pullout construction
- Flanged outer column with integral bearing bracket
- Enclosed or semi-open impellers
- Oil, freshwater or self-lubricating column construction
- Seal chamber accepts packing or mechanical seal
- Three-piece rigid, adjustable motor coupling
- Shaft sleeves under the bearings and seal chamber
- Options
  - Discharge head with integral axial thrust bearing assembly
  - Cast or fabricated bowl assembly
  - Integrated suction bell bearing bracket
  - Multiple stages
  - Thrust collar
  - Sand cap
- Engineered to customer specifications

See Bulletin PS-40-6.

**AFV**  
**Vertical, Axial Flow**



**Standards**

- Flowserve

**Operating Parameters**

- Flows to 181 700 m<sup>3</sup>/h (800 000 gpm)
- Heads to 11 m (35 ft)
- Speeds to 1770 rpm
- Sizes from 200 mm (8 in) to 3.1 m (123 in)
- Settings to 8 m (25 ft)

**Features**

- Three- or four-vane axial flow design
- Cast or fabricated bowl assembly
- Flanged outer column pipe with integral bearing bracket
- Oil, freshwater or self-lubricating lineshaft construction
- Fabricated discharge with mitered elbow
- Above- or below-ground discharge
- Multiple drive options
  - Solid or hollow shaft motor
  - Steam turbine
  - Diesel engine
- Options
  - Casing liners
  - Integral axial thrust bearing assembly

See Bulletin PS-40-3.

**CVP**  
**Vertical, Concrete Volute**

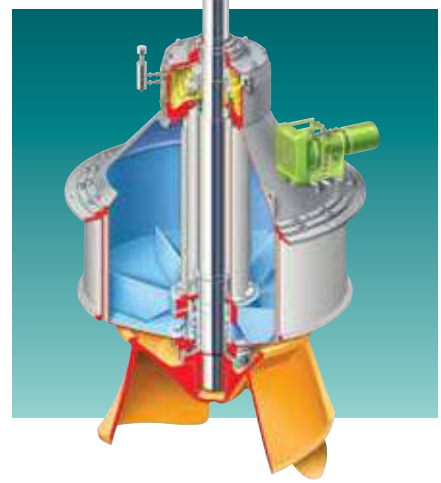

**Standards**

- Flowserve
- Hydraulic Institute

**Operating Parameters**

- Flows to 200 000 m<sup>3</sup>/h (800 000 gpm)
- Heads to 60 m (197 ft)

**Features**

- Vertical dry-pit design
- Removable metallic pump pullout unit within a concrete volute
- Suction bell connected to preformed high-efficiency, vortex-free concrete suction box
- Open mixed flow and closed mixed flow impeller options
- Dry shaft design
- No submerged bearings
- Bearings and sealing systems easily accessible
- Prefabricated concrete segments
- Highly corrosion and erosion resistant
- Liquidyne® or mechanical shaft seal
- Inflatable static seal
- Engineered to customer specifications

**Available Configurations**

- BSV open mixed flow impeller design
- BCV closed mixed flow impeller design

See Bulletin PS-40-1.

© Liquidyne is a registered trademark of IHC.

**QLC and QLQC**  
**Vertical, Double Case,**  
**Double-Suction,**  
**Double Volute**

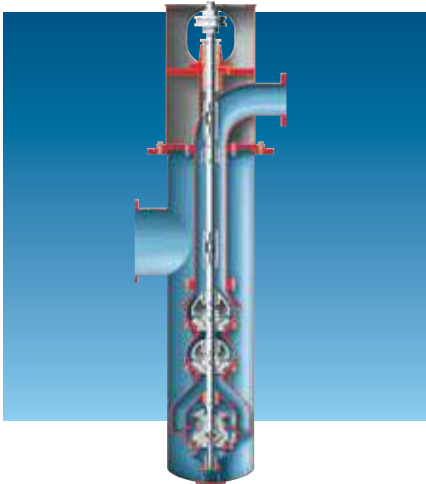

**Standards**

- Flowsolve
- ASME Sections VIII and IX

**Operating Parameters**

- Flows to 25 000 m<sup>3</sup>/h (110 000 gpm)
- Heads to 500 m (1640 ft)
- Pressures to 70 bar (1015 psi)
- Temperatures from -45°C (-50°F) to 204°C (400°F)

**Features**

- Double case construction
- Heavy-wall double volute casing
- Double-suction, first-stage impeller
- Open lineshaft construction
- Seal chamber accommodates cartridge-style single, dual unpressurized and dual pressurized mechanical seals
- Heavy-duty discharge head
- Options
  - ISO 13709/API 610 (VS7), latest ed., compliant designs
  - Directive 94/9/EC (ATEX 100) available
  - Hollow or solid shaft motor with thrust bearing
  - Antifriction (self-lubricated) or tilting pad axial thrust bearing assembly
  - Rigid, adjustable spacer coupling

**Available Configurations**

- QLC double case, single-stage
- QLQC double case, multistage
- QL single-stage
- QLQ multistage

See Bulletin PS-40-4.

**VPC**  
**Vertical Turbine,**  
**Double Case**



**Standards**

- ASME Sections VIII and IX
- Hydraulic Institute
- AWWA

**Operating Parameters**

- Flows to 13 600 m<sup>3</sup>/h (60 000 gpm)
- Heads to 1070 m (3500 ft)
- Pressures to 100 bar (1450 psi)
- Temperatures from -45°C (-50°F) to 230°C (450°F)

**Features**

- Diffuser design
- Above- or below-grade discharge
- ASME Class 150 or 300 slip-on flanges
- Single or multistage designs
- Enclosed or semi-open impellers
- Large eye first-stage impeller
- Product or oil bearing lubrication
- Flanged column pipe
- High-pressure stuffing box
- Rigid, adjustable flanged coupling
- Drive options
  - Hollow or solid shaft motor
  - Variable speed drive
  - Engine with right angle gear
  - Steam turbine
- Other options
  - Integral axial thrust bearing assembly
  - O-ring construction
  - Keyed impellers
  - Bowl and impeller wear rings

**Related Configurations**

- VTP vertical turbine

See Bulletin PS-40-2.

**WUC (VS6)**  
**Vertical, Double Case,**  
**Multistage**

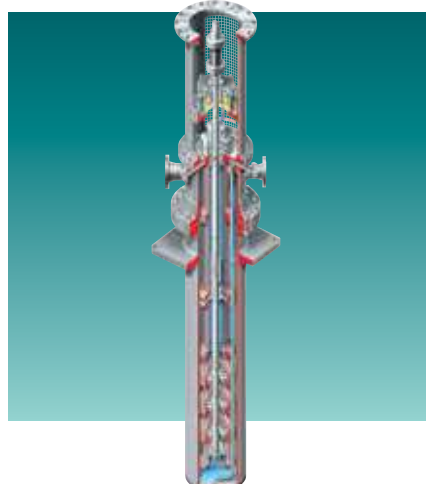

**Standards**

- ISO 13709/API 610 (VS6), latest ed.
- ASME Sections VIII and IX
- German Pressure Vessel Association (AD)
- British Standard BS 5500
- Compliance with Pressure Equipment Directive 97/23/EC

**Operating Parameters**

- Flows to 3000 m<sup>3</sup>/h (13 200 gpm)
- Heads to 2000 m (6560 ft)
- Pressures to 200 bar (2900 psi)
- Temperatures from -200°C (-328°F) to 350°C (660°F)

**Features**

- Radial or mixed flow hydraulics
- Low suction velocity can design
- Optional axial thrust tilting pad bearing configuration
- Stiff shaft design
- ISO 21049/API 682 seal chamber accommodates multiple seal types
- Flanged spacer coupling
- Screen-type, non-sparking coupling guard
- Inside drain line
- Casing and impeller wear rings
- Reinforced motor stand
- Optional inducer

**Related Configurations**

- WUJ (VS1) vertical line shaft, multistage
- WUC-LNG cryogenic (VS6) double case, multistage

See Bulletin PS-40-9.

**APKD**  
**Vertical, Double Case,**  
**Double-Suction**



**Standards**

- Flowserve

**Operating Parameters**

- Flows to 4600 m<sup>3</sup>/h (20 200 gpm)
- Heads to 500 m (1640 ft)
- Pressures to 50 bar (725 psi)
- Temperatures from -18°C (0°F) to 95°C (200°F)
- Speeds to 1800 rpm

**Features**

- Double-suction, first-stage impeller
- Double case construction
- Impellers keyed with lock collars
- Double volute casing
- Heavy-duty discharge head
- Open lineshaft construction
- Flanged column assembly with bearing retainers
- Large shaft with keyed lineshaft couplings
- Mechanically sealed
- Rigid, adjustable flanged coupling
- Solid shaft motor with NEMA or IEC thrust bearing
- Optional suction can drain

**Related Configurations**

- APKC single-suction design

See Bulletin PS-40-10.

## **Pleuger SUBM Deep-Well Submersible (Water-Filled Design)**



### **Standards**

- Flowserve
- CSA, WIMES 3.03, EMV, KTV, CE, VDE and other certifications

### **Operating Parameters**

- Flows to 6000 m<sup>3</sup>/h (26 415 gpm)
- Heads to 800 m (2625 ft)
- Motor sizes to 5000 kW (6700 hp)
- Speeds from 200 to 3600 rpm

### **Features**

- Wet-type motors with watertight insulated windings
- Dynamically balanced impellers
- Pre-filled motors with food grade additives
- Heavy-duty, adjustable, self-aligning thrust bearings
- Friction-welded shafts
- Non-toxic Class Y winding insulation for potable water services
- Variable frequency drive and high-temperature options
- Choice of materials
  - Cast iron
  - Bronze
  - Austenitic stainless steels
  - Duplex stainless steels
  - Reinforced composite

### **Related Configurations**

- Byron Jackson SUBM deep-well submersible (oil-filled design)

See Bulletin PS-50-3.

## **Byron Jackson SUBM Deep-Well Submersible (Oil-Filled Design)**

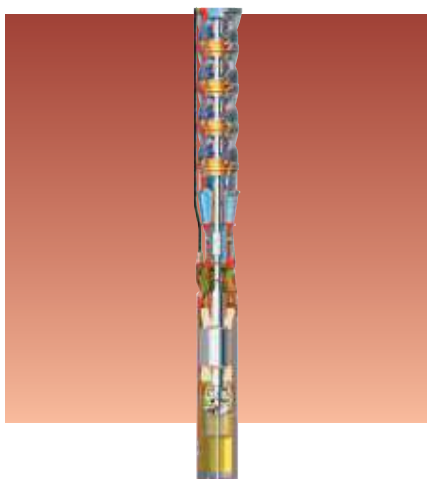

### **Standards**

- Flowserve
- NSF Standard 61 Certification
- Certification program accredited by RvA, Dutch Council for Accreditation

### **Operating Parameters**

- Flows to 6000 m<sup>3</sup>/h (26 415 gpm)
- Heads to 800 m (2625 ft)
- Motor sizes to 1650 kW (2200 hp)
- Speeds from 1000 to 3600 rpm

### **Features**

- Oil-filled motors with self-contained force feed, filtered, cooled oil circulation system
- Vacuum pressure impregnated (VPI) epoxy, Class F insulation system
- Double-acting thrust bearing system
- Dynamically balanced, heavy-duty, high-efficiency impellers
- Variable frequency drive and high-temperature options
- Choice of materials
  - Cast iron
  - Bronze
  - Austenitic stainless steels
  - Duplex stainless steels
  - Reinforced composite
- Choice of seals
  - Mercury seal
  - Double mechanical seal
  - Single, pressurized mechanical seal

### **Related Configurations**

- Pleuger SUBM deep-well submersible (water-filled design)

See Bulletin PS-50-3.

## **MSX Solids Handling, Submersible**

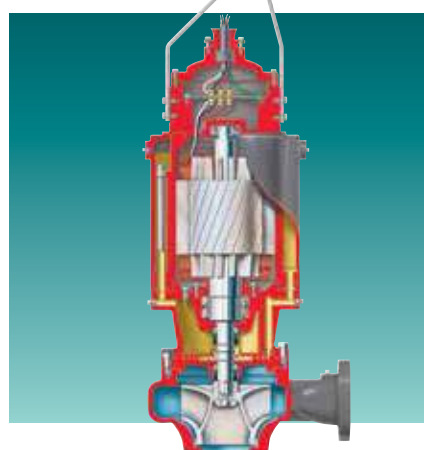

### **Standards**

- Flowserve

### **Operating Parameters**

- Flows to 4545 m<sup>3</sup>/h (20 000 gpm)
- Heads to 90 m (300 ft)
- Temperatures to 40°C (104°F)
- Discharge sizes from 80 mm (3 in) to 500 mm (20 in)
- Motor ratings to 224 kW (300 hp)
- Solids handling to 80 mm (3 in) diameter spherical

### **Features**

- High-efficiency hydraulics
- EPACT-rated motor
- Spike-resistant windings
- Class H insulation system
- Dynamically balanced shaft and rotor
- Mounting options
  - Wet-pit
  - Dry-pit
  - Transportable

### **Available Configurations**

- MSX Series 1: sizes from 75 mm (3 in) to 150 mm (6 in)
- MSX Series 2/3: sizes to 500 mm (20 in)

See Bulletin PS-50-2.

**MVX**  
**Solids Handling, Wet-Pit**



- Standards**
- Flowserve

**Operating Parameters**

- Flows to 17 000 m<sup>3</sup>/h (75 000 gpm)
- Heads to 40 m (130 ft)
- Sizes 250 mm (10 in) to 1200 mm (48 in)
- Drivers to 950 kW (1250 hp)
- Solids up to 150 mm (6 in)

**Features**

- Heavy-duty fabricated discharge head designed with fabricated flange and splitter vane
- Symmetrical bowl with multi-volute design
- Hydraulically balanced design
- Enclosed non-clog impeller
- Enclosed lineshaft
- Splitter vane in the column and discharge head
- Mechanical seal or soft packing shaft sealing options
- Hollow or solid shaft motor style
- 416 stainless steel lineshafts
- Separate steel soleplate
- Bronze lineshaft bearings
- Suction bell
- Standard suction bell wear rings
- Optional impeller wear rings

See Bulletin PS-40-5.

**MFV**  
**Solids Handling**

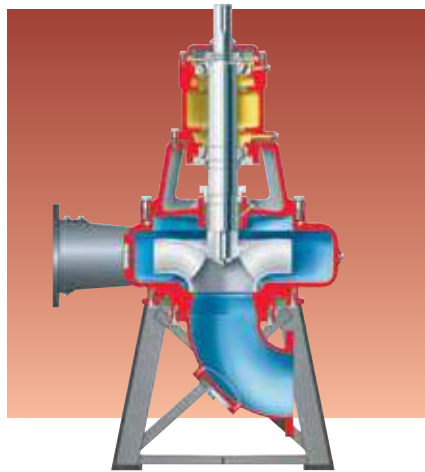

- Standards**
- Flowserve

**Operating Parameters**

- Flows to 2275 m<sup>3</sup>/h (10 000 gpm)
- Heads to 90 m (300 ft)
- Sizes to 400 mm (16 in)

**Features**

- Variety of nozzle position options
- Direct or independent motor mounting
- Minimal shaft deflection
- Oversized shaft and reduced overhang
- Hardened chrome steel wear rings
- Seal chamber accommodates packing or mechanical seals
- Adjustable impeller clearance
- Shaft sleeve options
  - 316 stainless steel
  - Hardened chrome steel
- Bearing housing features
  - Ball or tapered roller bearings
  - Integral jacking bolts for wear ring adjustment
  - Accessible lubrication points

**Available Configurations**

- MF horizontal, end suction
- MFV vertical with motor on separate floor (shown)
- MFC vertical with direct connected motor

See Bulletin PS-10-3.

**MNV**  
**Large Capacity, Solids Handling**

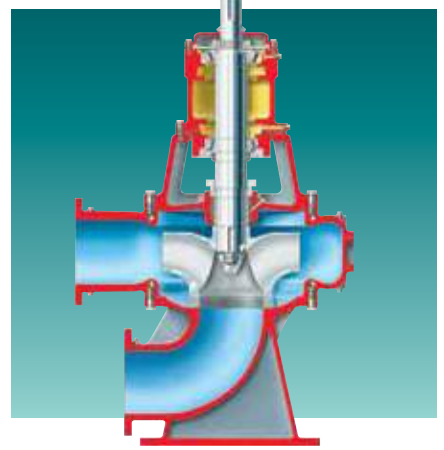

- Standards**
- Flowserve

**Operating Parameters**

- Flows to 45 500 m<sup>3</sup>/h (200 000 gpm)
- Heads to 90 m (300 ft)
- Sizes to 1800 mm (72 in)

**Features**

- Variety of nozzle position options
- Direct or independent motor mounting
- Minimal shaft deflection
- Oversized shaft and reduced overhang
- Hardened chrome steel wear rings
- Seal chamber accommodates packing or mechanical seals
- Adjustable wear ring clearance
- Shaft sleeve options
  - 316 stainless steel
  - Hardened chrome steel
- Bearing housing features
  - Tapered roller bearings
  - Integral jacking bolts for wear ring adjustment
  - Accessible lubrication points

**Available Configurations**

- MN horizontal, end suction
- MNF vertical, bottom suction, direct connected motor
- MNZ vertical, bottom suction, motor on separate floor
- MNC vertical with base elbow, direct connected motor
- MNV vertical with base elbow, motor on separate floor (shown)

See Bulletin PS-10-4.

## FRBHJC Cantilever Sump

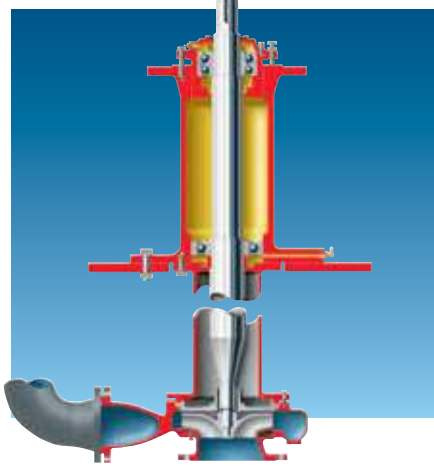

### Standards

- Flowserve

### Operating Parameters

- Flows to 2700 m<sup>3</sup>/h (12 000 gpm)
- Heads to 100 m (330 ft)
- Temperatures to 150°C (300°F)
- Speeds to 1780 rpm

### Features

- True stiff shaft cantilever design, without bottom bearing or flushing water
- Steep head capacity
- Semi-open, full vane impeller with back pump-out vanes
- Direct-coupled or V-belt driven
- Extra heavy-duty alloy steel shaft

### Related Configurations

- FRBH heavy-duty paper stock and process
- FRBHJ vertical lineshaft sump

See Bulletin PS-10-16.

## MJ and MJC Hard Metal, Slurry Sump



### Standards

- Flowserve

### Operating Parameters

- Flows to 1350 m<sup>3</sup>/h (6000 gpm)
- Heads to 30 m (100 ft)
- Pressures to 10 bar (150 psi)
- Temperatures to 110°C (225°F)
- Solids from 2% to 70% by weight
- Speeds to 1780 rpm

### Features

- Abrasion- and corrosion-resistant high chrome iron concentric casing
- Integrally cast straightening vanes in the suction nozzle
- Closed impeller with pump-out vanes on front and rear shrouds
- MJ has fluted cutlass rubber bearings
- MJC has restriction bushing
- Directly coupled or V-belt driven
- Options
  - Hard metal expeller
  - Open and recessed impellers
  - Choice of materials

### Available Configurations

- MJ submerged bearing and lineshaft design
- MJC cantilever design
- M horizontal, hard metal, abrasive slurry

See Bulletin PS-10-19.

## RJ and RJC Rubber-Lined, Slurry Sump

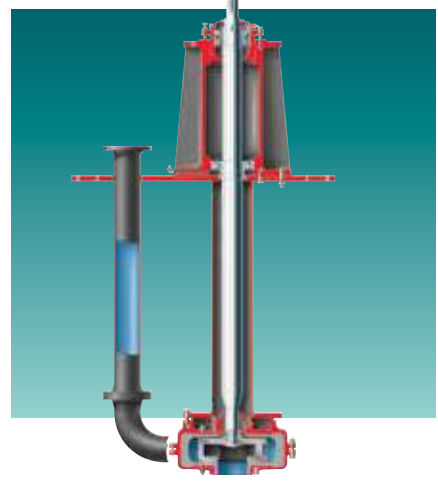

### Standards

- Flowserve

### Operating Parameters

- Flows to 1350 m<sup>3</sup>/h (6000 gpm)
- Heads to 30 m (100 ft)
- Pressures to 10 bar (150 psi)
- Temperatures to 110°C (225°F), depending on material
- Solids from 2% to 70% by weight
- Speeds to 1780 rpm

### Features

- Radially split casing with anti-rotation vanes in suction nozzle
- Casing liners pressure molded on steel backing plates; multiple materials available
- Rubber, pressure-molded closed impeller with pump-out vanes on front and rear shrouds
- RJ has fluted cutlass rubber bearings
- RJC has restriction bushing
- Directly coupled or V-belt driven
- Options
  - Hard metal expeller
  - Choice of liner materials

### Available Configurations

- RJ submerged bearing and lineshaft design
- RJC cantilever design
- R horizontally split, rubber lined, slurry

See Bulletin PS-10-18.

## Terra-Titan Cantilever Sump



### Standards

- Flowserve

### Operating Parameters

- Flows to 250 m<sup>3</sup>/h (1100 gpm)
- Heads to 45 m (150 ft)
- Pressures to 5 bar (70 psi)
- Temperatures to 100°C (212°F)
- Sizes from 40 mm (1.5 in) to 125 mm (5 in)
- Sump depths from 700 mm (28 in) to 1800 mm (72 in)

### Features

- One-piece suspended, oversized cantilever shaft construction
- Interchangeable urethane or hard metal wetted parts
- Concentric casing design
- Double-suction, hydraulically balanced open impeller
- External impeller adjustment
- Renewable Terraprene urethane shaft sleeve
- Greased-for-life, heavy-duty, self-aligning roller bearings
- Upper and lower strainers
- Run-dry capability
- ANSI and ISO configurations
- Portable
- Lifting lugs
- Rigid motor mount pivot bar
- Available bottom suction tailpipe
- Multiple drive options

See Bulletin PS-10-7.

## MSX Solids Handling, Submersible

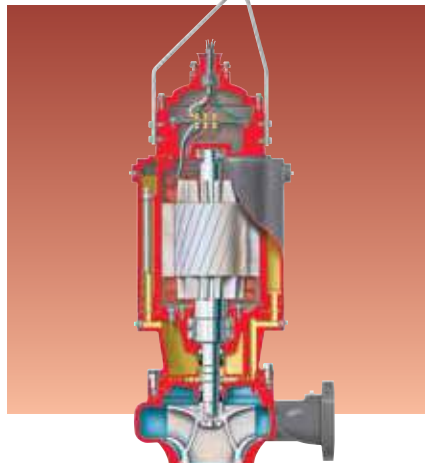

### Standards

- Flowserve

### Operating Parameters

- Flows to 4545 m<sup>3</sup>/h (20 000 gpm)
- Heads to 90 m (300 ft)
- Temperatures to 40°C (104°F)
- Discharge sizes from 80 mm (3 in) to 500 mm (20 in)
- Motor ratings to 224 kW (300 hp)
- Solids handling to 80 mm (3 in) diameter spherical

### Features

- High-efficiency hydraulics
- EPACT-rated motor
- Spike-resistant windings
- Class H insulation system
- Dynamically balanced shaft and rotor
- Mounting options
  - Wet-pit
  - Dry-pit
  - Transportable

### Available Configurations

- MSX Series 1: sizes from 75 mm (3 in) to 150 mm (6 in)
- MSX Series 2/3: sizes to 500 mm (20 in)

See Bulletin PS-50-2.

## Drain-Titan Urethane-Lined, Double-Suction Sump

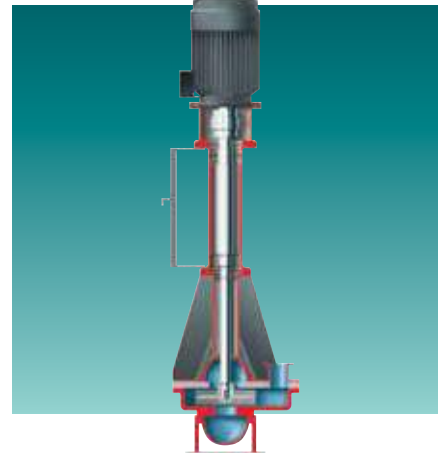

### Standards

- Flowserve

### Operating Parameters

- Flows to 160 m<sup>3</sup>/h (700 gpm)
- Heads to 40 m (130 ft)
- Pressures to 4 bar (55 psi)
- Sizes from 40 mm (1.5 in) to 100 mm (4 in)
- Solids to 15 mm (0.6 in)

### Features

- Double-suction, urethane-coated, wet end
- Robust, integral unit construction
- Large diameter, stiff cantilever drive shaft
- No submerged bearings or seals
- Double-sided impeller with pre-set clearance
- Keyed and bored shaft coupling
- Standard single lip oil seal
- Urethane-lined, slotted outlet pipe flange
- Grease-lubricated, single row, deep groove ball bearings
- No priming required
- Run-dry capability

See Bulletin PS-10-7.

## CPXV Chemical Sump



### Standards

- ISO 13709/API 610, 8th & 10th ed.
- ISO 5199

### Operating Parameters

- Flows to 1400 m<sup>3</sup>/h (6160 gpm)
- Heads to 250 m (820 ft)
- Pressures to 25 bar (365 psi)
- Temperatures from -40°C (-40°F) to 350°C (660°F)

### Features

- Heavy-duty casing with multi-ribbed discharge flange
- High-efficiency, semi-open impeller
- Column lengths to 10 m (32 ft)
- Heavy-duty thrust bearings with axial adjustment above soleplate level
- Accepts multiple seal arrangements
- Elastomeric split element coupling
- Options
  - Recessed impeller
  - Suction strainer
  - Spacer coupling
  - Rectangular or circular soleplate
  - Oil lubrication to thrust bearing
  - Zone Ø hazardous area beneath soleplate configuration
- CE marked and compliant with applicable European directives such as ATEX; available with GOST certification

### Other Configurations

- CPXVR recessed impeller, chemical sump
- Fully jacketed, molten salt design

See Bulletin PS-10-30.

## ESP3 Chemical Sump



### Standards

- Flowserve

### Operating Parameters

- Flows to 1300 m<sup>3</sup>/h (5700 gpm)
- Heads to 90 m (300 ft)
- Pressures to 12 bar (175 psi)
- Temperatures to 180°C (350°F)

### Features

- Optimized lineshaft bearing design to ISO 13709/API 610 spacing requirements
- Double row external thrust bearings
- Single and duplex configurations
- Flanged discharge
- Large basket strainer
- Industry standard TCV motors
- Lubrication options
  - Product lube for clear liquids
  - Dual particle separator for light solids
  - Grease lubrication
- Mounting plate sealing options
  - Vapor-tight
  - Vapor-proof
  - Pressurized design
- Options
  - Upper stuffing box
  - Sealing ring
  - Suction tailpipes
  - Level controls

### Related Configurations

- ESP3 Lo-Flo
- ESP3 recessed impeller
- ESP3 high chrome iron

See Bulletin PS-10-24.

## PolyChem VGRP Engineered Polymer Composite Sump

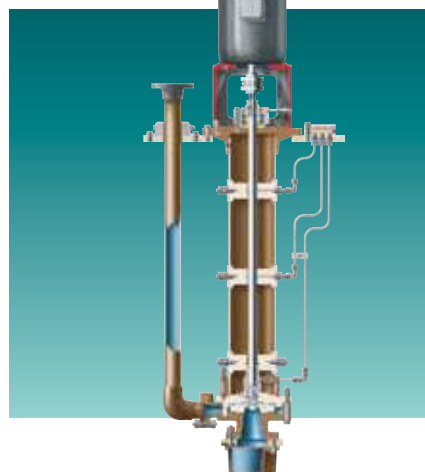

### Standards

- Flowserve

### Operating Parameters

- Flows to 565 m<sup>3</sup>/h (2500 gpm)
- Heads to 110 m (350 ft)
- Pressures to 17 bar (250 psi)
- Temperatures from -30°C (-20°F) to 90°C (200°F)

### Features

- Glass-reinforced vinyl ester
- Unitized casing with integrally molded, fully gusseted suction and discharge flanges
- Externally adjustable, semi-open impeller
- Shaft and bearing system operates well below the first critical speed
- Self-lubricated or external flush bearings
- Single-piece, lightweight, filament-wound, reinforced fiberglass composite column
- Single and duplex configurations
- Full basket strainer
- NEMA in-line motor
- Fiberglass mounting plate
- Tapered polygon impeller drive
- Pullout bearing retainers
- Level controls
- Choice of shaft metallurgy

### Related Configurations

- PolyChem GRP engineered polymer composite

See Bulletin PS-10-17.



## Drain-Titan Urethane-Lined, Double-Suction Sump

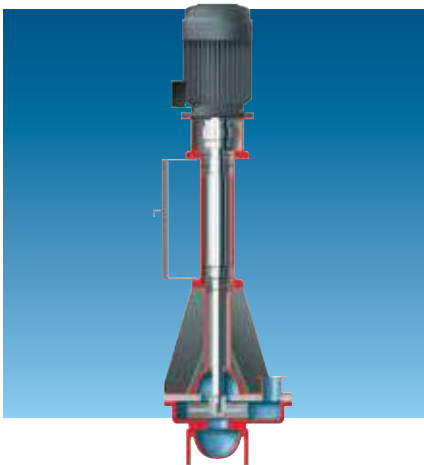

### Standards

- Flowserve

### Operating Parameters

- Flows to 160 m<sup>3</sup>/h (700 gpm)
- Heads to 40 m (130 ft)
- Pressures to 4 bar (55 psi)
- Sizes from 40 mm (1.5 in) to 100 mm (4 in)
- Solids to 15 mm (0.6 in)

### Features

- Double-suction, urethane-coated wet end
- Robust, integral unit construction
- Large diameter, stiff cantilever drive shaft
- No submerged bearings or seals
- Double-sided impeller with pre-set clearance
- Keyed and bored shaft coupling
- Standard single lip oil seal
- Urethane-lined, slotted outlet pipe flange
- Grease-lubricated, single row, deep groove ball bearings
- No priming required
- Run-dry capability

See Bulletin PS-10-7.

## VSMP Vertical Standard Motor



### Standards

- Flowserve

### Operating Parameters

- Flows to 135 m<sup>3</sup>/h (600 gpm)
- Heads to 70 m (220 ft)
- Pressures to 12 bar (175 psi)
- Temperatures from -40°C (-40°F) to 120°C (250°F)

### Features

- Glass-reinforced polymer, high-efficiency, semi-open or closed impellers standard
- Industry standard NEMA motors
- Stainless steel, self-aligned mechanical seal
- Back pullout design
- Clamp-type mounting plate
- Options
  - Cast iron, bronze or 316 stainless steel impellers
  - Stub shaft design

### Related Configurations

- SMP standard motor pump
- SMX non-metallic standard motor pump

See Bulletin PS-10-26.

## ECPJ (VS4) Sump



### Standards

- ISO 13709/API 610 (VS4), latest ed.

### Operating Parameters

- Flows to 1000 m<sup>3</sup>/h (4400 gpm)
- Heads to 150 m (500 ft)
- Pressures to 20 bar (285 psi)
- Temperatures to 350°C (660°F)
- 45 sizes available

### Features

- Lineshaft configuration
- Four impeller designs
  - Closed multivane impeller with front wear rings and back vanes
  - Closed multivane impeller with front and rear wear rings
  - Open multivane impeller with back vanes
  - Free flow impeller with back vanes
- Multiple shaft sealing options
  - V-ring
  - Throttle bushing
  - Lip seal with grease-filled stuffing box
  - Soft packing
- ISO 21049/API 682 seal chamber accommodates multiple seal types
- Column lengths to 6 m (22 ft); suction pipe available
- Choice of ISO/API materials
- NACE MR0175 materials available
- Internal or external bearing flushing
- Bearing cooling
- Suction strainer

See Bulletin PS-10-10.

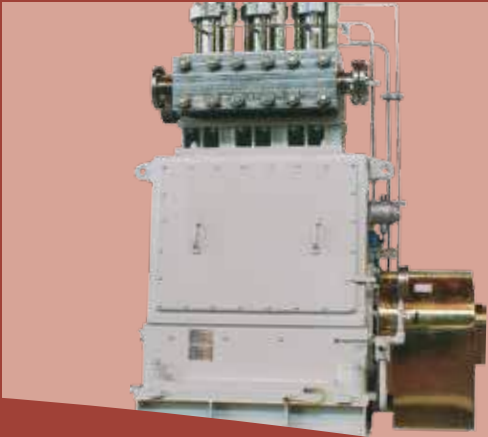



## ***Positive Displacement***

### ***Gear***

<i>GR Series</i>	52
<i>GA Series</i>	52
<i>Gearex</i>	52

### ***Screw***

<i>TSP</i>	53
<i>MP1</i>	53
<i>MP1 Systems Packaging</i>	53

### ***Reciprocating***

<i>YHT</i>	54
<i>HS</i>	54
<i>VTE</i>	54
<i>VQE</i>	54
<i>V</i>	54
<i>VSE</i>	54

## GR Series Double Helical, Gear

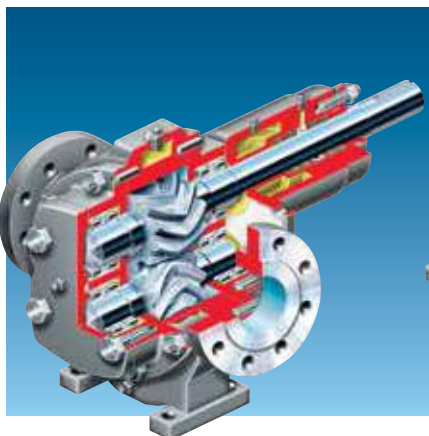

### Standards

- Flowsolve

### Operating Parameters

- Flows to 275 m<sup>3</sup>/h (1200 gpm)
- Pressures to 35 bar (500 psi)
- Temperatures to 350°C (650°F)
- Speeds to 1800 rpm
- Viscosities to 20 000 cP

### Features

- Double helical, herringbone gears
- Quiet, pulse-free flow
- High-speed pump capability
- Between bearings design
- Hydraulically balanced design
- Stuffing box accommodates packing or mechanical seals
- High-capacity, double row roller bearing
- Self-priming
- Run-dry capability
- Low NPSHR
- Back pullout design
- Options
  - Mechanical seal
  - Direct V-belt drive
  - Extra deep jacketed stuffing box
  - Jacketed body
  - Babbitted carbon sleeve bushing
  - INSUROCK® wearplates
  - Integral safety relief valve

### Available Configurations

- GR standard gear width
- GRW wide gears for high flows
- GRH narrow gears for high pressures

See Bulletin PS-60-4.

## GA Series Double Helical, Gear

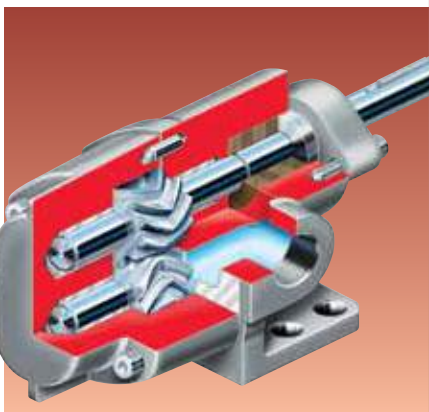

### Standards

- Flowsolve

### Operating Parameters

- Flows to 27 m<sup>3</sup>/h (120 gpm)
- Pressures to 17 bar (250 psi)
- Temperatures to 175°C (350°F)
- Speeds to 1800 rpm
- Viscosities to 5000 cP

### Features

- Double helical, herringbone gears
- Quiet, pulse-free flow
- High-speed pump capability with off-the-shelf motors
- Between bearings design
- Self-lubricated babbitted carbon sleeve bearings standard; bronze bearings optional
- Hydraulically balanced design requires no thrust bearings
- Convertible stuffing box accommodates packing or mechanical seals
- Threaded ports
- Back pullout design
- Available integral safety relief valve
- Multiple mounting configurations

### Related Configurations

- GAS foot mounting (standard)
- GAF flange mounting
- GAC close coupled
- GSX series stainless steel, double helical, rotary gear pumps

See Bulletin PS-60-4.

## Georex Double Helical, Timed Gear

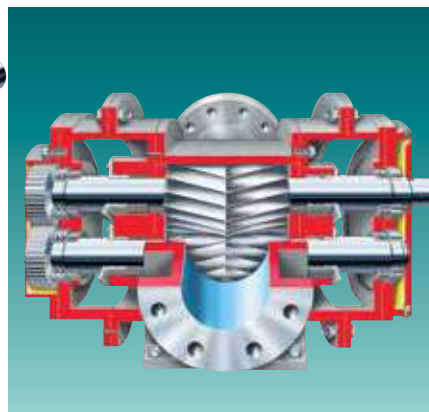

### Standards

- Flowsolve

### Operating Parameters

- Flows to 180 m<sup>3</sup>/h (800 gpm)
- Pressures to 20 bar (300 psi)
- Temperatures from -50°C (-60°F) to 450°C (842°F)
- Viscosities to 20 000 cP

### Features

- Double helical, herringbone gears
- Quiet, pulse-free flow
- External timing gears
- Between bearings design
- Heavy-duty, double row roller bearings
- Direct coupled
- Options
  - Water-cooled bearings
  - Steam- or water-jacketed bodies
  - Vertical mounting configuration
  - Mechanical seals
  - Lantern rings
  - Shaft slingers
  - Split bearing brackets
  - Flange mounting brackets
  - Jackshafts for V-belt drives

See Bulletin PS-60-4.

## TSP Double-Suction, Twin-Screw

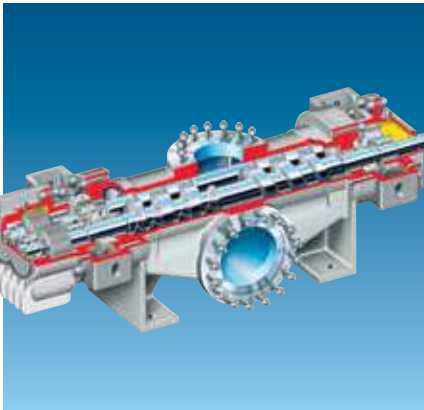

### Standards

- API 676, latest ed.

### Operating Parameters

- Flows to 2550 m<sup>3</sup>/h (11 200 gpm)
- Pressures to 100 bar (1450 psi)
- Temperatures to 450°C (842°F)
- Speeds to 1800 rpm
- Viscosities to 55 million cP
- Slurry concentrations to 70% by weight

### Features

- Positive displacement timed two-screw
- Double-suction design
- Split bearing bracket for ease of maintenance
- Versatile ISO 21049/API 682 compliant stuffing box design
- Integral or pinned screw elements
- Spur-tooth timing gears
- Chrome-plated pump bores
- Options
  - Fully external bearings and timing gears
  - Internal bearings and timing gears
  - Temperature control packages
  - Hopper-top construction
  - Vertical barge configuration
  - Choice of materials
  - Multiple hard coatings for bores and screws

See Bulletin PS-60-1.

## MP1 Multiphase Twin-Screw

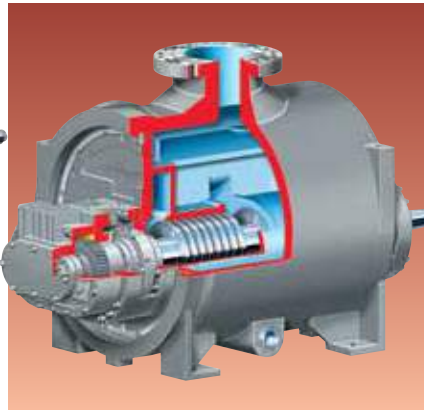

### Standards

- API 676, latest ed.

### Operating Parameters

- Flows to 2255 m<sup>3</sup>/h (9617 gpm)
- Pressures to 50 bar (720 psi)
- Temperatures to 450°C (842°F)
- Speeds to 2000 rpm
- Viscosities to 8000 cP
- Multiphase pumping to 100% GVF (gas volume fractions)

### Features

- Non-contacting design with one-piece pump shafts
- Three pumping locks for low pulsation flow
- Through-bolt bearing bracket design
- ISO 21049/API 682 seal chamber with split brackets accommodates single and double cartridge seals
- Double-suction design with low NPSH capability
- AGMA 11 helical timing gears
- Chrome-plated bores and hard-coated screws
- Options
  - Multiple hard coatings for bores and screws
  - Choice of materials, including NACE
  - Customized pitch
  - Customized packaging
  - Variable speed drive
  - Natural gas or diesel engine drive

### Other Configurations

- High pressure: 100 bar (1450 psi)

See Bulletin PS-60-2.

## MP1 Systems Packaging



### Standards

- Flowserve
- ASME

### Features

- Standard or custom engineered system packaging available
- Driver options
  - Electric motor
  - Electric motor with variable speed drive (VSD)
  - Diesel or natural gas engine
- Complete piping systems
  - Suction, discharge, bypass and recycle piping
  - Block, control and check valves
  - Filters and strainers
  - Pressure, temperature and flow instrumentation
- Complete, integrated control systems
  - PLC-based
  - Controls for pump, valves, instrumentation and alarms, VSD, etc.
  - Motor control center
- Single and multiple skid options for integration of controls, pump and piping
- Special enclosures for arctic-like conditions or other harsh environments

## YHT and HS Horizontal Reciprocating

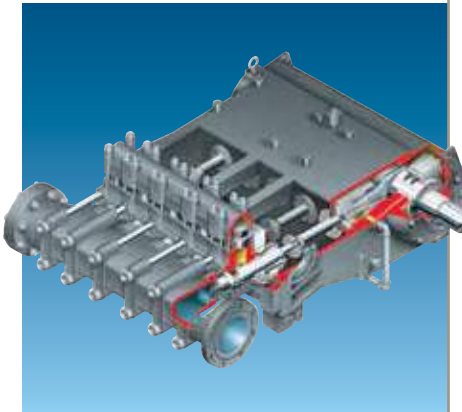

### Standards

- API 674, latest ed.
- ASME section III

### Operating Parameters

- 75 mm (3 in) to 250 mm (10 in) stroke
- Flows to 775 m<sup>3</sup>/h (3400 gpm)
- Standard pressures to 555 bar (8030 psi); custom pressures to 2070 bar (30 000 psi)
- Temperatures from -40°C (-40°F) to 350°C (650°F)
- Power to 2560 kW (3430 hp)
- Speeds to 530 rpm

### Features

- Self-aligning plungers
- Sectionalized fluid end components
- Fully enclosed power end with generous oil reservoir
- Independent crosshead extension rod
- Integrally cast and precision-machined cylindrical crosshead guides
- Triple lip seal at crosshead extensions
- Fully reversible crankshaft for V-belt drive or direct coupling
- Stuffing box assemblies individually bolted to fluid cylinder
- Splash-type or full-pressure lubrication system
- Threaded primary drain
- Options
  - Overhead motor mounting
  - Spring-loaded stuffing box
  - Discharge pulsation dampeners

See Bulletin PS-70-1.

## VTE, VQE, V and VSE Vertical Reciprocating

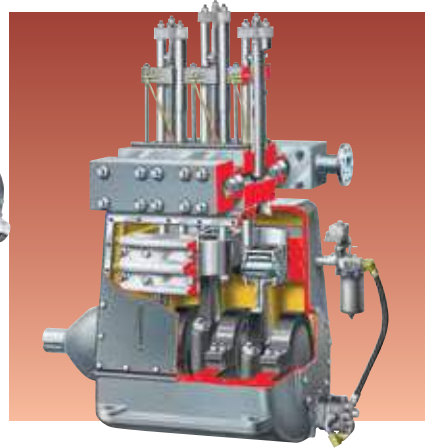

### Standards

- API 674, latest ed.
- ASME section III

### Operating Parameters

- 140 mm (5.5 in) to 225 mm (9 in) stroke
- Flows to 1140 m<sup>3</sup>/h (5000 gpm)
- Standard pressures to 619 bar (8975 psi); custom pressures to 2070 bar (30 000 psi)
- Temperatures from -40°C (-40°F) to 350°C (650°F)
- Power to 3450 kW (4625 hp)
- Speeds to 360 rpm

### Features

- Outboard packed inverted design
- Easily accessible stuffing box
- Integrated suction and discharge manifold
- Complete separation of liquid end from power end
- Valve design suitable for conditions of service
- Spherical feature for plunger alignment
- Power-end maintenance inspection covers
- Forced feed lubrication
- Options
  - Spring-loaded packing
  - Pulsation dampeners
  - Sectionalized fluid ends

See Bulletin PS-70-1.







## Specialty Products

### **Nuclear Pumps and Seals**

<i>DFSS</i>	58
<i>DVSS</i>	58
<i>N-Seal</i>	58
<i>WDF</i>	58
<i>DVSR</i>	59
<i>CN</i>	59
<i>HDR</i>	59
<i>CA</i>	60
<i>CAM</i>	60
<i>CAV</i>	60
<i>EG</i>	61
<i>MEV</i>	61

### **Extreme Temperature**

<i>WUC-LNG Cryogenic</i>	62
<i>VKW Cryogenic</i>	62
<i>TKW Cryogenic</i>	62
<i>Byron Jackson</i>	62
<i>SUBM Geothermal</i>	

### **Others**

<i>Hydraulic Decoking Systems</i>	63
<i>IPS Products</i>	63
<i>Pleuger WFSD</i>	64
<i>Azimuthing Thruster</i>	
<i>DWEER™</i>	64
<i>ERT</i>	64
<i>CVP</i>	65
<i>Barge Pump</i>	65
<i>Molten Salt VTP</i>	65



## DFSS and DVSS Nuclear Radially Split, Single-Stage

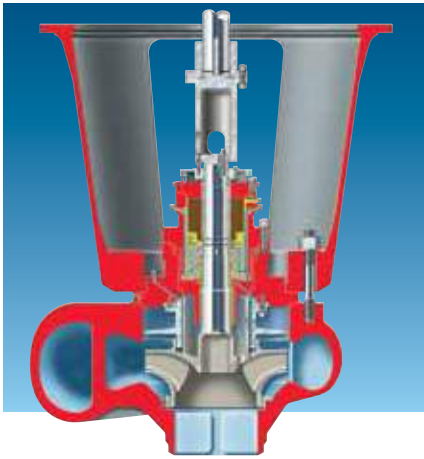

### Standards

- ASME Section III, Class 1

### Operating Parameters

- Flows to 24 500 m<sup>3</sup>/h (108 000 gpm)
- Heads to 250 m (820 ft)
- Pressures to 170 bar (2500 psi)
- Temperatures to 300°C (580°F)
- Speeds to 1800 rpm
- Power rating to 9400 kW (12 600 hp)

### Services

- Primary coolant
- Reactor recirculation
- Primary heat transport

### Features

- Fourth generation design
- One-piece cast pump casing
- Double volute design case for BWR and PHWR
- Diffuser with torus-type design casing for PWR
- Upgraded rotating element
  - One-piece welded shaft-impeller-journal assembly
  - Fully machined and balanced as single rotating unit
- Hydrostatic-pressurized radial bearing
  - Operates submerged in radioactive system water at loop temperature of approximately 300°C (580°F)

See Bulletin FPD-2.

## N-Seal Nuclear Mechanical Seals



### Standards

- ASME Section III, Class 1

### Operating Parameters

- Pressures to 150 bar (2175 psi)
- Temperatures to 80°C (180°F)
- Speeds to 1800 rpm

### Services

- Primary coolant
- Reactor recirculation
- Primary heat transport

### Features

- Controlled leakage seal design
- Design life of five years or 50 000 hours
- Reduced man-rem exposure
- Unique one- or two-piece cartridge construction
- Two-, three- and four-stage configurations
- Assured redundancy with each stage able to handle full system pressure
- Interchangeable stage components
- Hydrodynamic seal face technology
- Three different seal face lift designs available
- Multiple seal face materials available
- Provisions for monitoring pressure, temperature and flow at each stage
- Internal screens for trapping particles
- Seal faces are supported by gaskets to minimize pressure points and deflection

See Bulletin PS-80-2.

## WDF Nuclear Vertical, Single-Stage

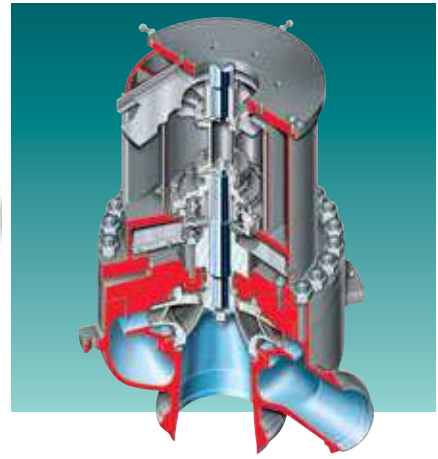

### Standards

- ASME Section III, Class 2 and 3

### Operating Parameters

- Flows to 900 m<sup>3</sup>/h (4000 gpm)
- Heads to 245 m (800 ft)

### Services

- Containment spray
- Low-pressure safety injection
- Residual heat removal

### Features

- Vertical, single-stage design
- Bottom suction, horizontal discharge
- Forged diffuser casing design
- Optimized hydraulic performance
- Unique spacer coupling design
- Mechanical seal replacement without motor or casing cover removal
- Upgraded rotor design
  - Radial bearing located between coupling and seal
  - Reduced shaft deflection
  - Improved pump and mechanical seal life and reliability
- Cartridge mechanical seal
- Reduced assembly time

See Bulletin FPD-2.

**DVSR Nuclear  
Radially Split, Volute  
Casing, Single-Stage**

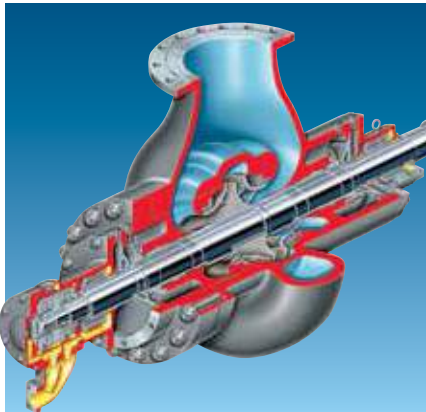

**Standards**

- ASME Section VIII

**Operating Parameters**

- Flows to 4535 m<sup>3</sup>/h (19 945 gpm)
- Heads to 800 m (2625 ft)
- Pressures to 100 bar (1470 psi)
- Temperatures to 210°C (410°F)
- Power to 8000 kW (10 700 hp)
- Speeds to 6000 rpm

**Services**

- Reactor and steam generator feedwater

**Features**

- Cast volute casing configuration
- Double cover design
- High-speed pump design
- Double-suction impeller
- Centerline mounted
- Pressure breakdown bushing or mechanical seal
- Sleeve radial and tilting pad thrust bearings standard

See Bulletin FPD-2.

**CN Nuclear  
Radially Split, Diffuser  
Casing, Single-Stage**

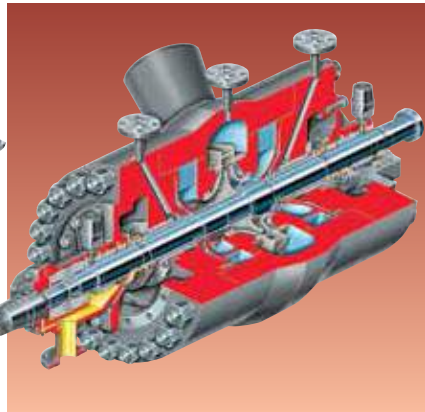

**Standards**

- ASME Section VIII

**Operating Parameters**

- Flows to 5065 m<sup>3</sup>/h (22 300 gpm)
- Heads to 800 m (2625 ft)
- Pressures to 100 bar (1470 psi)
- Temperatures to 210°C (410°F)
- Power to 11 200 kW (15 000 hp)
- Speeds to 6000 rpm

**Services**

- Reactor and steam generator feedwater

**Features**

- Diffuser casing configuration
- Forged barrel
- High-speed pump design
- Double-suction impeller
- Special impeller designs for low NPSHA conditions
- Centerline mounted
- Pressure breakdown bushing or mechanical seal
- Sleeve radial and tilting pad thrust bearings standard

See Bulletin PS-80-4.

**HDR Nuclear  
Radially Split, Volute  
Casing, Single-Stage**

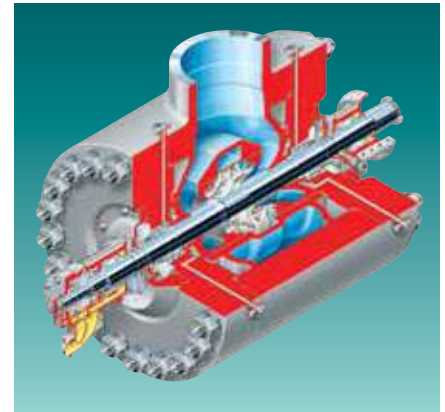

**Standards**

- ASME Section VIII

**Operating Parameters**

- Flows to 5065 m<sup>3</sup>/h (22 300 gpm)
- Heads to 800 m (2625 ft)
- Pressures to 100 bar (1470 psi)
- Temperatures to 210°C (410°F)
- Power to 11 200 kW (15 000 hp)
- Speeds to 6000 rpm

**Services**

- Reactor and steam generator feedwater

**Features**

- Volute casing configuration
- Forged barrel
- High-speed pump design
- Double-suction impeller
- Special impeller designs for low NPSHA conditions
- Centerline mounted
- Pressure breakdown bushing or mechanical seal
- Sleeve radial and tilting pad thrust bearings standard

**CA Nuclear  
Diffuser Casing,  
Multistage, Utility Barrel**

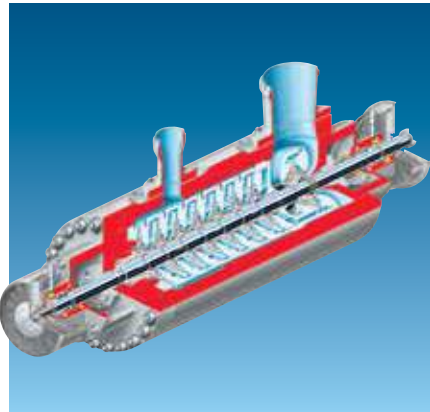

**Standards**

- ASME Section III, Class 2 and 3

**Operating Parameters**

- Flows to 5250 m<sup>3</sup>/h (23 000 gpm)
- Discharge pressures to 450 bar (6500 psi)
- Temperatures to 250°C (480°F)
- Speeds to 6000 rpm

**Services**

- Safety injection

**Features**

- Internal casing with segmented stage elements
- Diffuser guide-vane construction
- Precision cast in-line impellers
- Heavy-duty forged barrel with forged steel discharge cover
- Balance drum and sleeve, made from hardened stainless forgings
- Ball thrust and ball radial bearings
- Fan-cooled bearing housings
- Renewable casing rings and sleeves
- Ground forged steel shafting
- Cartridge seals

See Bulletin FPD-2.

**CAM Nuclear  
Diffuser Casing,  
Multistage, Utility Barrel**

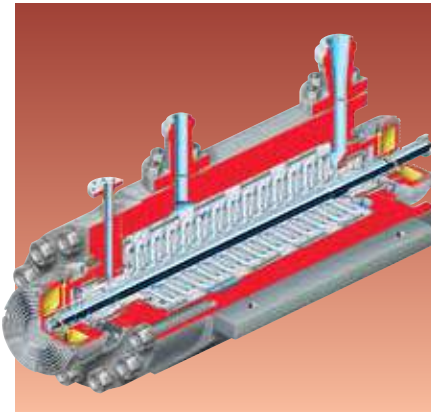

**Standards**

- ASME Section III, Class 2 and 3

**Operating Parameters**

- Flows to 45 m<sup>3</sup>/h (200 gpm)
- Heads to 1920 m (6300 ft)
- Pressures to 235 bar (3410 psi)
- Temperatures to 120°C (250°F)

**Services**

- CVCS charge
- Control rod drive

**Features**

- Multistage, double case design
- Unique, compact design
- Modular impellers
  - Low-flow stability and reliability over a wide range of flows
  - No surging or pulsations
- Ball-ball construction
- Dry disk spacer coupling
- Flanged axial thrust balancing device
- Modularized assembly and disassembly may be conducted without the use of a torch
- Forged barrel with no attachment welds
- Cartridge mechanical seals with no attachment welds
- No auxiliary cooling required

See Bulletin FPD-2.

**CAV Nuclear  
Vertical, Double Case,  
Multistage**

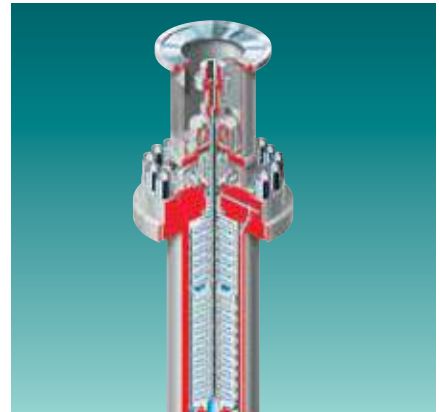

**Standards**

- ASME Section III, Class 2 and 3

**Operating Parameters**

- Flows to 60 m<sup>3</sup>/h (265 gpm)
- Heads to 2000 m (6560 ft)
- Pressures to 235 bar (3410 psi)
- Temperatures to 100°C (212°F)
- Speeds to 3600 rpm

**Services**

- CVCS charge

**Features**

- Multistage, double case design
- Barrel-rated at full discharge pressure
- Suction and discharge connections at bottom of barrel
- Diffuser design with back-to-back impeller mounting to minimize thrust
- Cartridge mechanical seal
- Thrust bearings provided in either pump or motor as required
- Spacer coupling

See Bulletin FPD-2.

## **EG Nuclear Radially Split, Double-Suction**

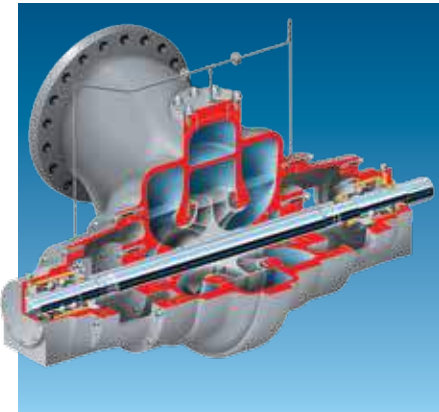

### **Standards**

- ASME Section III, Class 3

### **Operating Parameters**

- Flows to 4000 m<sup>3</sup>/h (17 610 gpm)
- Heads to 60 m (200 ft)
- Pressures to 14 bar (200 psi)
- Temperatures to 80°C (180°F)
- Power to 950 kW (1275 hp)
- Speeds to 3600 rpm

### **Services**

- Component cooling water

### **Features**

- Cast volute casing
- Double cover design
- Double-suction impeller
- Centerline mounting
- Side suction and side discharge located above the mounting feet
- Cartridge mechanical seal
- 360° bearing housings
- Ball radial and ball thrust bearings

See Bulletin FPD-2.

## **MEV Nuclear Vertical, Single-Stage**

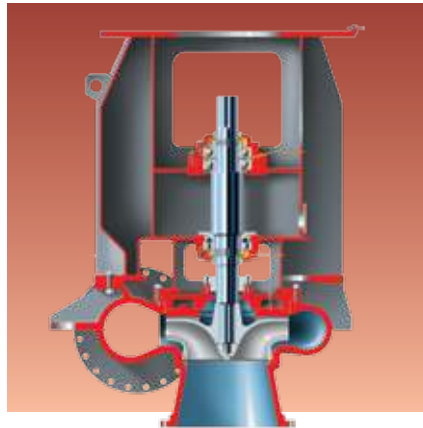

### **Standards**

- ASME Section III, Class 3

### **Operating Parameters**

- Flows to 5400 m<sup>3</sup>/h (23 760 gpm)
- Heads to 50 m (160 ft)
- Pressures to 14 bar (200 psi)
- Temperatures to 80°C (180°F)
- Speeds to 3600 rpm

### **Services**

- Essential and non-essential service water

### **Features**

- Cast casing and cover
- Bottom suction, horizontal discharge configuration
- Single-stage, enclosed impeller
- Fabricated motor stand
- Cartridge mechanical seal
- Radial roller and double ball thrust bearings
- Grease-lubricated bearings

See Bulletin FPD-2.

## WUC-LNG Cryogenic (VS6) Vertical, Double Case, Multistage

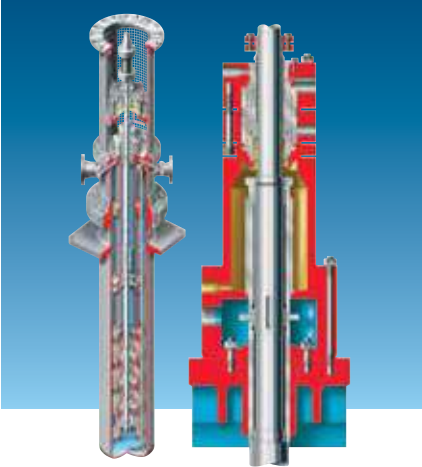

### Standards

- ISO 13709/API 610 (VS6), latest edition
- ASME Sections VIII and IX
- German Pressure Vessel Association (AD)
- British Standard BS 5500
- Compliance with Pressure Equipment Directive 97/23/EC

### Operating Parameters

- Flows to 3000 m<sup>3</sup>/h (13 000 gpm)
- Heads to 1200 m (3900 ft)
- Pressures to 200 bar (3000 psi)
- Temperatures from -200°C (-328°F) to -45°C (-50°F)

### Features

- Cofferdam system
- Radial or mixed flow hydraulics
- Low suction velocity can design
- Optional axial thrust tilting pad bearing configuration
- Stiff shaft design
- ISO 21049/API 682 compliant mechanical seal chamber
- Flanged spacer coupling
- Screen-type, non-sparking coupling guard
- Inside drain line
- Casing and impeller wear rings
- Reinforced motor stand
- Optional inducer

### Related Configurations

- WUC (VS6) double case, multistage

See Bulletin PSS-40-9.1.

## VKW and TKW Cryogenic Liquid Expander (VS6) Double Case, Multistage, Electric Generator

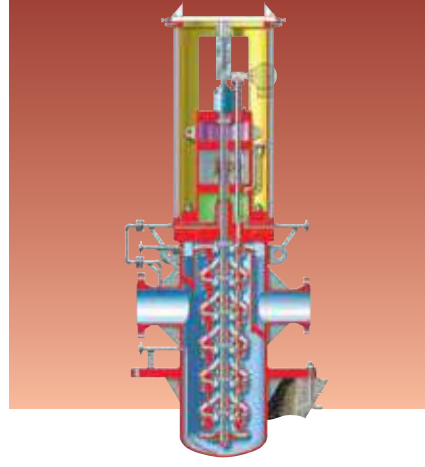

### Standards

- ISO 13709/API 610 (VS6), latest edition
- ASME Sections VIII and IX

### Operating Parameters

- Expander flows to 2500 m<sup>3</sup>/h (11 000 gpm)
- Inlet pressures to 70 bar (1000 psi)
- Temperatures to -180°C (-290°F)
- Power to 3 MW (4000 hp)
- Runaway speed to 5400 rpm

### Features

- Variable or fixed geometry
- Externally driven remote and local controlled variable wickets
- Optimal isentropic efficiency
- Overall improvement of compressor power efficiency
- Air-cooled generator
- Temperature reduction through liquid expansion
- Additional electric generation
- Low vibration
- Low noise level
- State-of-the-art gas seal
- Optimum specific speed selection

### Available Configurations

- TKW variable geometry, double case, multistage, electric generator
- VKW fixed geometry, double case, multistage, electric generator

See Bulletin PSS-90-7.1.

## Byron Jackson SUBM Geothermal Deep-Well Submersible



### Standards

- IEC/VDE and other certifications

### Operating Parameters

- Flows to 720 m<sup>3</sup>/h (3170 gpm)
- Heads to 800 m (2625 ft)
- Temperatures to 160°C (320°F)
- Motor sizes to 1500 kW (2000 hp)
- Speeds from 2900 to 3500 rpm
- Inner well diameters from 340 mm (13-3/8 in) to 508 mm (20 in)

### Features

- Pump and motor design for geothermal application
- Oil-filled motor with self-contained force feed, filtered, cooled oil circulation system
- Vacuum pressure impregnated (VPI) epoxy, Class F insulation system
- Class C winding insulation system
- Double cable plug construction
- Double-acting thrust bearing system
- Dynamically balanced heavy-duty, high-efficiency impellers
- Optional variable frequency
- Choice of materials
- Double mechanical seal
- Motor design with breather diaphragm for pressure compensation
- Non-return design for high pressure
- Downhole monitoring system

### Other Configurations

- Byron Jackson SUBM deep-well submersible (oil-filled design)

## Hydraulic Decoking Systems

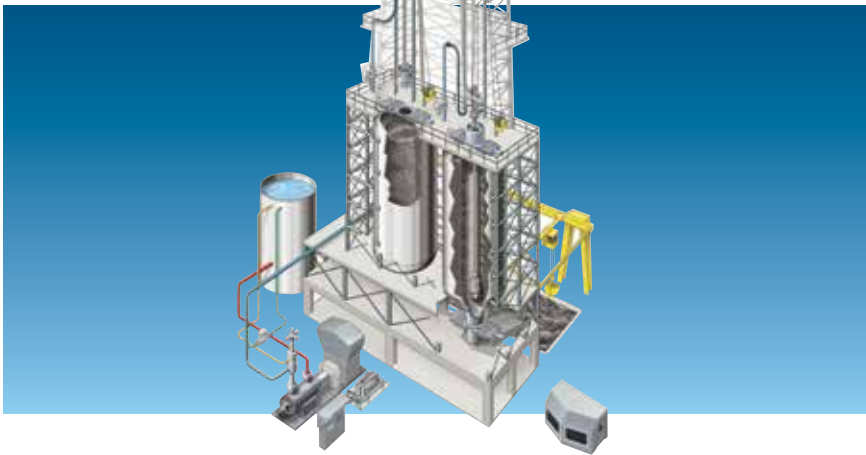

### Flowserve Automated Hydraulic Decoking Systems

- Increase delayed coking unit (DCU) capacity and improve operator safety
- Installed in more than 95% of the world's DCUs
- Complete systems with virtually all equipment needed to operate and control the hydraulic decoking process
- Extensive aftermarket support including specialists to evaluate system performance, improve reliability, and recommend operational and safety best practices

### Complete Coke Cutting Systems

- Jet pump train: ISO 13709/API 610 (BB5) jet pump, driver, lube oil skid and control system panel
- Coke cutting system: decoking control valve, AutoShift™ combination cutting tool, rotary joint, isolation and bleed valves, drill stem, tool guide and enclosure and high-pressure hose
- Cutting assembly lifting system: crosshead, free-fall arresters, winches and winch controls, pulley blocks, and latch mechanism to stow the crosshead
- Automation, controls and instrumentation

### AutoShift Combination Cutting Tool

- Removes the operator from the cutting deck
- Mode shifting is accomplished automatically and remotely by water pressurization and depressurization

- Provides greater system automation and improved efficiency while improving operator safety, reducing cycle time and easing maintenance
- Mode shifting helps to free impeded tools from slumped beds

### Advanced Cutting Control

- Complete systems and enclosures to monitor and control the operations
- Continuous feedback signals indicate equipment and drum status (i.e., position in drum, rotational speed, wore rope tension, etc.)
- Embedded intelligence to process data for monitoring and control; operator interface only required for sequence exception
- Video and acoustic equipment to monitor cutting deck operations and coke chute conditions
- Remote winch and rotary joint operation
- Remote sensing of cutting jet impingement on the coke drum
- Interlocking safety systems
- IPS APEX™ data monitoring, transmission and control systems

### Online Assurance Programs

- Access to data aggregation tools via the Technology Advantage™ Portal
- Enable experts to monitor, diagnose and communicate operating solutions to increase unit uptime

See Bulletin PS-90-6.

## IPS Equipment Monitoring and Control Products



### Intelligent Process Solutions (IPS)

- Family of equipment monitoring and control products that helps to proactively manage plant assets
  - Collect key system parameters
  - Analyze and synthesize data into actionable information
  - Protect process equipment via automated responses
  - Transmit information to enable a timely manual response
- Increase uptime
- Reduce operating costs

### IPS Wireless

- Cost-effective and scalable data acquisition system
- Open platform architecture
- Omni-directional technology

### IPS APEX

- Advanced diagnostics
- Intelligent control algorithms protect against high-risk process conditions

### IPS Tempo

- Variable frequency drive
- Intelligent system optimization

### IPS Power Monitor

- Monitors actual power usage
- Programmable start-up delay and low and high trip points

See Bulletin PS-90-11.

## Pleuger WFSD Azimuthing Thruster

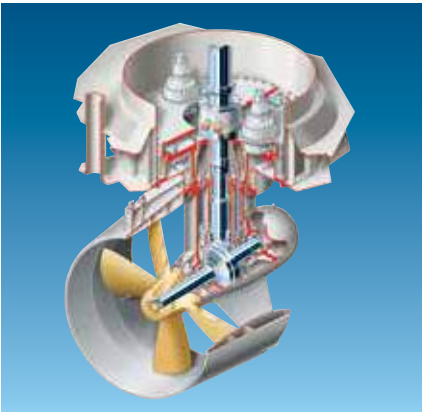

### Standards

- Flowserve

### Applications

- Semi-submersible drilling rigs
- Floating production, storage and offloading vessels
- Drill ships
- Crane vessels and pipelay vessels

### Features

- Up to 5 m (16.5 ft) propeller diameter
- Up to 4500 kW (6000 hp) input
- 4- or 5-blade fixed pitch propeller
- 7° tilted propeller shaft
  - Propulsion and steering with thrust in any direction
  - Minimal thruster-hull and thruster-thruster interaction for higher net thruster output
  - Mounting and dismantling underwater without dry-docking
  - Customization to meet specific application needs
- Duplex thrust bearing allows windmilling at any speed
- Automatic pressure compensation system adapts differential pressure to draft
- Fully flooded gear housing provides optimum lubrication
- Easy underwater mounting; secured during installation by hydraulically operated locking mechanism
- Fully redundant closed-loop hydraulic steering system as standard

See Bulletin PSS-90-8.1.

## DWEER™ Dual Work Exchange Energy Recovery



### Standards

- Flowserve

### Operating Parameters

- Brine flows to 350 m<sup>3</sup>/h (1.4 MGD); greater flows can be achieved by placing multiple DWEER units in parallel
- Pressures to 75 bar (1090 ft)

### Features

- Highest efficiency energy recovery device available
- Noise levels below 83 dBa
- Self-adjustable to changing operating conditions
- Super duplex stainless steel or fiber-reinforced plastic pressure vessel
- No leakage lubrication required
- LinX™ valve regulates flow into vessels
- Proven long-term reliability
- Capable of passing solids (no additional strainers required)
- System responsibility with integrated controls
- Slow operating speed
- Smooth increase and decrease of system pressure during startup and shutdown

See Bulletin FPD-18.

## ERT Energy Recovery Turbine



### Standards

- Flowserve

### Operating Parameters

- Brine flow to 1200 m<sup>3</sup>/h (5280 gpm)
- Pressures to 80 bar (2715 ft)
- Efficiency up to 90%
- Power to 1500 kW (2025 hp)
- Special designs available on request

### Features

- Specially designed for sea water reverse osmosis (SWRO) applications
- Standardized product line
- Wetted parts in super duplex stainless steel and non-metallics
- Proven long-term reliability with more than 25 years of operating experience
- Simple plant integration and control
- Horizontal split casing
- External standard bearings
- Labyrinth double seals
- Flat operating curve over typical RO performance range
- No mixing, overflush or leakage

See Bulletin FPD-18.



## CVP Vertical, Concrete Volute



### Standards

- Flowserve
- Hydraulic Institute

### Operating Parameters

- Flows to 200 000 m<sup>3</sup>/h (800 000 gpm)
- Heads to 60 m (197 ft)

### Features

- Vertical dry-pit design
- Removable metallic pump pullout unit within a concrete volute
- Suction bell connected to preformed high-efficiency, vortex-free concrete suction box
- Open mixed flow and closed mixed flow impeller options
- Dry shaft design
- No submerged bearings
- Bearings and sealing systems easily accessible
- Prefabricated concrete segments
- Highly corrosion and erosion resistant
- Liquidyne® or mechanical shaft seal
- Inflatable static seal
- Engineered to customer specifications

### Available Configurations

- BSV open mixed flow impeller design
- BCV closed mixed flow impeller design

See Bulletin PS-40-1.

© Liquidyne is a registered trademark of IHC.

## Barge Pump

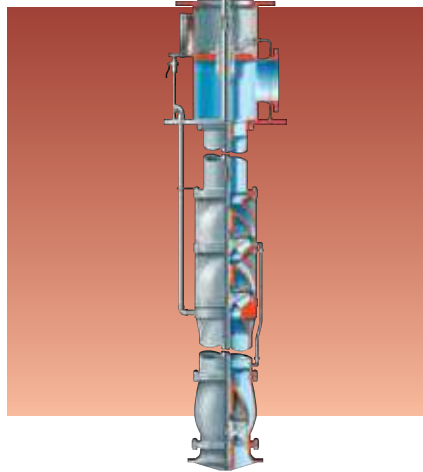

### Standards

- Flowserve

### Operating Parameters

- Flows to 1020 m<sup>3</sup>/h (4500 gpm)
- Heads to 185 m (600 ft)
- Pressures to 8.6 bar (125 psi)
- Temperatures from -30°C (-20°F) to 230°C (450°F)
- Discharge flanges to 250 mm (10 in)

### Features

- Pollution prevention design
- Discharge head with access ports
- Rabbeted-fit motor shaft to headshaft
- 1.5 m (5 ft) column pieces with integrally fabricated bearing support
- Automatic stuffing box bleed-off and valved drain line
- Special low NPSH priming stage impeller
- Semi-open series stage impeller
- Automatic air separation chamber with continuous seal

See Bulletin PSS-40-7.2.

## Molten Salt VTP

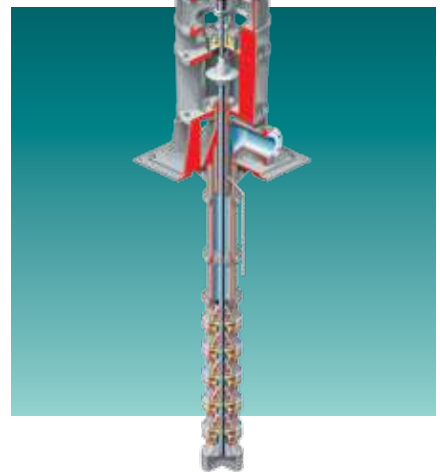

### Standards

- Flowserve

### Operating Parameters

- Flows to 13 600 m<sup>3</sup>/h (60 000 gpm)
- Heads to 530 m (1740 ft)
- Pressures to 100 bar (1450 psi)
- Temperatures to 600°C (1100°F)
- Settings to 20 m (65 ft)

### Features

- Low pump submergence allows for greater energy generation
- Low NPSHR for enhanced suction performance
- Excellent heat dissipation prevents distortion at high temperatures
- Advanced fluid sealing system
- Materials engineered to equalize thermal growth and forestall distortion
- Wet-pit or tank-mounted
- Dynamically balanced enclosed impellers
- Flanged column pipe with open lineshaft construction
- Product lubricated bearings
- Cooling fan/disc
- Drain tubes
- Other options
  - Integral axial thrust bearing
  - Thrust-balanced impeller
  - Coupling bellows
  - ISO 13709/API 610 construction

### Related Configurations

- FRBHJC cantilever sump
- CPXV chemical sump

See Bulletin FPD-16.

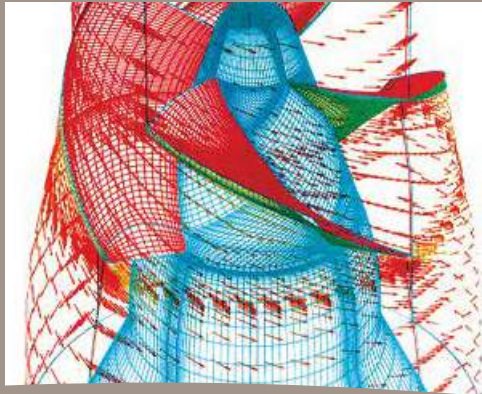

**Additional Information**

<i>Services and Solutions</i>	68
<i>Other Flowserve Products</i>	70
<i>Reference Sources</i>	71





## Services and Solutions for the Global Infrastructure Markets

The business and operational challenges within a process plant are numerous. Plant operators face the pressures of increased productivity and profits that are seemingly at odds with the everyday realities of decreased operating budgets, rising energy costs and increasing operational costs. But Flowserve Services and Solutions can help relieve the stresses and reduce the life cycle costs associated with the most important aspects of plant operation. Dedicated to delivering the highest quality support, Flowserve Services and Solutions integrates hydraulic, mechanical, and materials engineering knowledge with creative operating and business solutions to:

- Improve equipment reliability and performance
- Reduce energy consumption
- Manage inventories
- Maintain flow management equipment



### Integrated Solutions That Support the Complete Life Cycle

Typically, 90% of the total life cycle cost (LCC) of a flow management system is accumulated after the equipment is purchased and installed. Flowserve offers a comprehensive suite of services and solutions designed to provide customers with unprecedented value and cost savings throughout the life span of the system.

- Asset Management and Optimization
- Engineering and Technical Services
- Education and Training
- Aftermarket Parts and Services



### ***Asset Management and Optimization***

Flowserve has developed the human resources, technology platforms and business alliances to help customers realize more payback from their plant assets.

- **Business Assessments** — Flowserve business consultants can benchmark operational performance, define the key metrics and implement the necessary steps to achieve specific goals.
- **Asset Data Management** — By employing sophisticated tools and technologies to collect, examine and understand data, Flowserve enables customers to reveal hidden opportunities for asset improvement.
- **Asset Optimization Solutions** — Flowserve offers a suite of performance-based contract services to address the key business and operational challenges of plant managers.

### ***Engineering and Technical Services***

With unrivaled engineering and technical resources in more than 55 countries, Flowserve delivers value-added solutions that improve operational performance and increase revenues for its customers.

- **Engineering Support** — Flowserve engineers can engage remotely or on-site to support grassroots project planning, system design or project management requirements.
- **Technical Assessments** — Flowserve can perform comprehensive system audits to identify operational issues that may be constraining output or elevating operating costs and propose solutions based upon life cycle cost (LCC) calculations.
- **Equipment Performance Improvements** — Flowserve routinely implements LCC-justified solutions to improve equipment performance, system throughput and unit profitability.

### ***Education and Training***

Flowserve offers a wide range of innovative programs to help plant operators, reliability specialists, engineers and maintenance personnel deepen their understanding of process systems.

- **Customer Site** — Flowserve can design, develop, and deliver training programs tailored specifically around the people, equipment and processes at a customer's facility.
- **Learning Resource Center** — At its state-of-the-art Learning Resource Centers, Flowserve provides hands-on training and instruction in the principles of equipment operation, maintenance and reliability.
- **Online** — Flowserve offers Web-based modules with online testing and data tracking to ensure comprehension of the most important principles.

### ***Aftermarket Parts and Services***

Investments in well-equipped Quick Response Centers, mobile service fleets, and advanced manufacturing technologies along with the unrivaled expertise of its engineers, technicians and craftsmen enable Flowserve to address virtually every service requirement for process equipment, on- or off-site, regardless of OEM.

- **Repair and Maintenance** — From machining to mechanical upgrades to on-site management, Flowserve repair and maintenance services focus on improving equipment performance while reducing downtime and costs.
- **Replacement Parts and Components** — Through quick response programs, rapid prototyping, and other innovative approaches, Flowserve can supply customers with the quality parts needed to keep operations running smoothly and profitably.

*Providing Complete Fluid Motion Control Equipment and Services*



## **Other Flowserve Products**

*Flowserve has the systems, products, and experience to help processes run smarter, safer and more efficiently. In addition to its extensive pump product line, Flowserve offers high-quality seals and valves.*

### **Flowserve Seals**

Flowserve manufactures and markets highly engineered mechanical shaft seals for containing corrosive, volatile, abrasive, precious or flammable fluid. They are used on pumps and other rotating equipment.

The complete seal line includes cartridge, dry-running, metal or elastomer bellows, split and zero-emission gas barrier seals. Offering innovative seal design and service on demand, Flowserve is committed to the development of new technologies to further reduce maintenance and operating costs for its customers.

### **Flowserve Valves**

With the industry's most complete range of valves, actuators, positioners, controls, switches and steam systems, Flowserve provides customers a one-stop solution for their flow control needs.

With comprehensive research and development, engineering and global support, Flowserve offers valve applications solutions from simple isolation service to intelligent process control.

To learn more about Flowserve valves and seals, visit [www.flowserve.com](http://www.flowserve.com).





## Reference Sources

### **FlowSelex™ Interactive Pump Selection Application**

FlowSelex is a Web-based interactive pump selection program that allows users to access an extensive database of Flowserve pump sizing information anytime, anywhere.

This versatile tool delivers a wide range of information, from pump descriptions and operating parameters to custom application package specifications with supporting technical documentation, including:

- Performance curves
- Hydraulic data sheets
- General arrangement drawings
- Construction data sheets

FlowSelex can be accessed at [www.Flowserve.com/FlowSelex](http://www.Flowserve.com/FlowSelex).



### **Cameron Hydraulic Data**

First published in 1926 and now in its 19th edition, the Cameron Hydraulic Data book is an indispensable aid to engineers involved with the specification, selection and application of pumping equipment. This comprehensive reference tool includes:

- Hydraulic principles and formulae
- Friction data
- Properties of common liquids
- Steam and electrical data
- Weights, dimensions, and ratings of pipe flanges and fittings
- Metric conversions

To obtain a copy of the Cameron Hydraulic Data book, visit: [www.cameronbook.com](http://www.cameronbook.com).

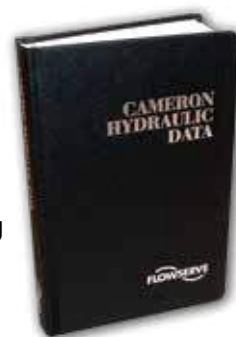

### **Pump Engineering Manual**

This publication is devoted to explaining centrifugal pump principles. It covers the basics, from application analysis and affinity laws through hydraulics and mechanical phenomena to troubleshooting.

To obtain a copy of the Pump Engineering Manual, visit: [www.cameronbook.com](http://www.cameronbook.com).



## Index



### A

<b>AFV</b> .....	41
<b>APKC</b> (see APKD) .....	43
<b>APKD</b> .....	43

### B

<b>Barge</b> .....	65
<b>BCV</b> (see CVP) .....	41, 65
<b>BP</b> .....	36
<b>BSV</b> (see CVP) .....	41, 65
<b>Byron Jackson SUBM</b> (Geothermal) .....	62
<b>Byron Jackson SUBM</b> (Oil-Filled Design) ..	44

### C

<b>CA</b> .....	60
<b>CAM</b> .....	60
<b>CAV</b> .....	60
<b>CHTA</b> .....	36
<b>CN</b> .....	59
<b>CPXS Magnetic Drive</b> .....	13
<b>CPXV Chemical Sump</b> .....	13, 48
<b>CSB</b> .....	35
<b>CSX</b> .....	34
<b>CVP</b> .....	41, 65

### D

<b>D800</b> .....	23
<b>DFSS</b> .....	58
<b>DMX</b> .....	30
<b>Drain-Titan</b> .....	47, 49
<b>DS</b> .....	24
<b>DSVP</b> .....	18
<b>DVSH</b> .....	28
<b>DVSR (non-nuclear)</b> .....	31
<b>DVSR (nuclear)</b> .....	59
<b>DVSS</b> .....	58
<b>DWEER</b> .....	64

### E

<b>EC</b> .....	30
<b>ECPJ</b> .....	49
<b>EG</b> .....	61
<b>ERPN</b> .....	17
<b>ERT</b> .....	64
<b>ESP3</b> .....	48

### F

<b>F-Line</b> .....	25
<b>FRBH</b> .....	21
<b>FRBHJC</b> .....	21, 46

### G

<b>GA Series</b> .....	52
<b>Gearex</b> .....	52
<b>GR Series</b> .....	52
<b>Guardian</b> .....	11

### H

<b>HDB</b> .....	36
<b>HDO</b> .....	37
<b>HDR</b> .....	59
<b>HDX</b> .....	31
<b>HDX-TT</b> .....	31
<b>HED</b> .....	32
<b>HED-DS</b> .....	32
<b>HPX</b> .....	16
<b>HPXM</b> .....	16
<b>HS</b> .....	54
<b>HSB</b> .....	36
<b>HSO</b> .....	37
<b>HWMA</b> .....	17
<b>HWMA2</b> (see HWMA) .....	17
<b>Hydraulic Decoking Systems</b> .....	63

### I

<b>IPS Products</b> .....	63
---------------------------	----

### L

<b>LC</b> .....	20
<b>LLR</b> (see LR) .....	28
<b>LNN</b> .....	28
<b>LPN</b> .....	29
<b>LR</b> .....	28
<b>LRV</b> (see LR) .....	28

### M

<b>M</b> .....	19
<b>Mark 3 ASME Standard</b> .....	10
<b>Mark 3 In-Line (ASME)</b> .....	11
<b>Mark 3 ISO Close Coupled</b> .....	13
<b>Mark 3 ISO Recessed Impeller</b> .....	12
<b>Mark 3 ISO Self-Priming</b> .....	12
<b>Mark 3 ISO Standard</b> .....	12
<b>Mark 3 Lo-Flo (ASME)</b> .....	10
<b>Mark 3 Recessed Impeller (ASME)</b> ..	11
<b>Mark 3 Unitized Self-Primer (ASME)</b> ..	10
<b>ME</b> .....	24
<b>MEN</b> .....	23
<b>MENBLOC</b> .....	23
<b>MEV</b> .....	61
<b>MF</b> .....	22
<b>MFV</b> .....	45
<b>MJ</b> .....	46
<b>MJC</b> .....	46
<b>MN</b> .....	22
<b>MND</b> .....	20
<b>MNR</b> .....	20
<b>MNV</b> .....	45
<b>Molten Salt VTP</b> .....	65
<b>MP1</b> .....	53
<b>MP1 Systems Packaging</b> .....	53
<b>MPT</b> .....	21



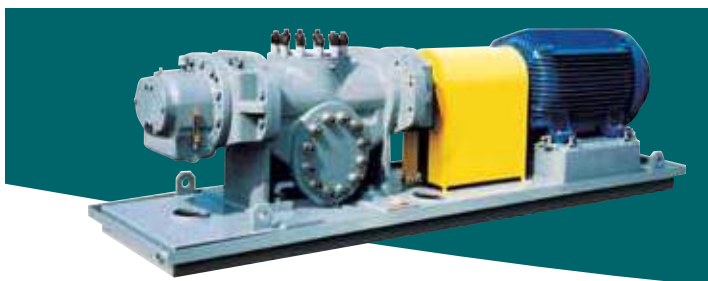

**MSP** ..... 18  
**MSP2** (see MSP) ..... 18  
**MSX** ..... 22, 44, 47  
**MVE** ..... 25  
**MXV** ..... 45

**N**

**NM** ..... 33  
**N-Seal** ..... 58

**P**

**PHL** ..... 16  
**Pleuger SUBM (Water-Filled Design)** ..... 44  
**Pleuger WFSD Azimuthing Thruster** ..... 64  
**Polybase** ..... 15  
**PolyChem GRP** ..... 14  
**PolyChem M-Series** ..... 15  
**PolyChem S-Series** ..... 14  
**PolyChem VGRP** ..... 14, 48  
**Polyshield** ..... 15  
**PVML** ..... 18  
**PVXM** ..... 17

**Q**

**QL** ..... 40  
**QLC** ..... 42  
**QLQ** ..... 40  
**QLQC** ..... 42

**R**

**R** ..... 19  
**RJ** ..... 46  
**RJC** ..... 46

**S**

**SMP** ..... 24  
**SMX** ..... 25  
**SUBM**  
 (see Byron Jackson SUBM or Pleuger SUBM) .. 44

**T**

**Terra-Titan** ..... 47  
**Titan Slurry** ..... 19  
**TKW Cryogenic Liquid Expander** ..... 62  
**TSP** ..... 53

**U**

**UZDL** ..... 30

**V**

**V** ..... 54  
**VCT** ..... 41  
**VKW** ..... 62  
**VPC** ..... 42  
**VQE** ..... 54  
**VSE** ..... 54

**VSMP** ..... 49  
**VTE** ..... 54  
**VTP** ..... 40

**W**

**WCC** ..... 37  
**WD** ..... 33  
**WDF** ..... 58  
**WDX** ..... 33  
**WFSD Thruster**  
 (see Pleuger WFSD Azimuthing Thruster) .... 64  
**WIK** ..... 37  
**WIKO** ..... 37  
**WMA** (see HWMA) ..... 17  
**WMA2** (see HWMA) ..... 17  
**WNC** ..... 35  
**WNC-HP** (see WNC) ..... 35  
**WTB** ..... 32  
**WUC** ..... 42  
**WUC-LNG** ..... 62  
**WUJ** ..... 40  
**WX** ..... 33  
**WXB** ..... 35  
**WXB-B** (see WXB) ..... 35  
**WXH** ..... 34

**Y**

**YHT** ..... 54





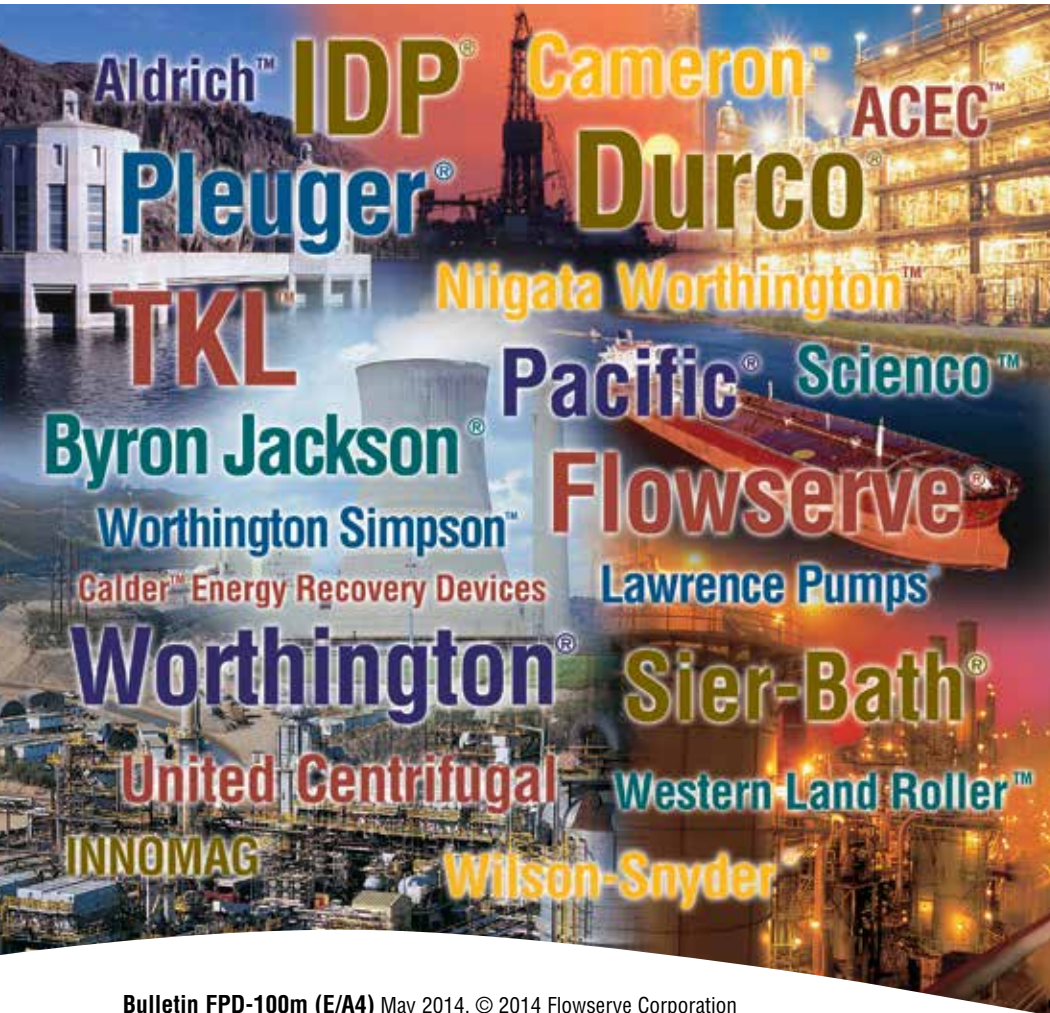

**USA and Canada**

Flowserve Corporation  
5215 North O'Connor Blvd.  
Suite 2300  
Irving, Texas 75039-5421 USA  
Telephone: +1 937 890 5839

**Europe, Middle East, Africa**

Flowserve Corporation  
Parallelweg 13  
4878 AH Etten-Leur  
The Netherlands  
Telephone: +31 76 502 8100

**Latin America**

Flowserve Corporation  
Martín Rodríguez 4460  
B1644CGN-Victoria-San Fernando  
Buenos Aires, Argentina  
Telephone: +54 11 4006 8700  
Telefax: +54 11 4714 1610

**Asia Pacific**

Flowserve Pte. Ltd.  
10 Tuas Loop  
Singapore 637345  
Telephone: +65 6771 0600  
Telefax: +65 6862 2329

Bulletin FPD-100m (E/A4) May 2014. © 2014 Flowserve Corporation

*To find your local Flowserve representative:*

For more information about Flowserve Corporation,  
visit [www.flowserve.com](http://www.flowserve.com) or call +1 937 890 5839.